

## FORD:

2004-2007 F-Super Duty

## ISSUE

Some 2004-2007 F-Super Duty vehicles, equipped with a power sliding rear window (back glass), may exhibit a stuck or binding concern. This condition may be due to the center glass not being positioned correctly inside the upper or lower channel, the channel being warped, bent, or center glass de-bonded.

## ACTION

Follow the Service Procedure steps to correct the condition.

## SERVICE PROCEDURE

1. Prior to window removal, verify that center glass is centered in the upper plastic channel (Figure 1). If center glass is not inside upper plastic channel, pull channel down and out of upper aluminum channel and slide back in making sure the entire center glass is inside the plastic channel.

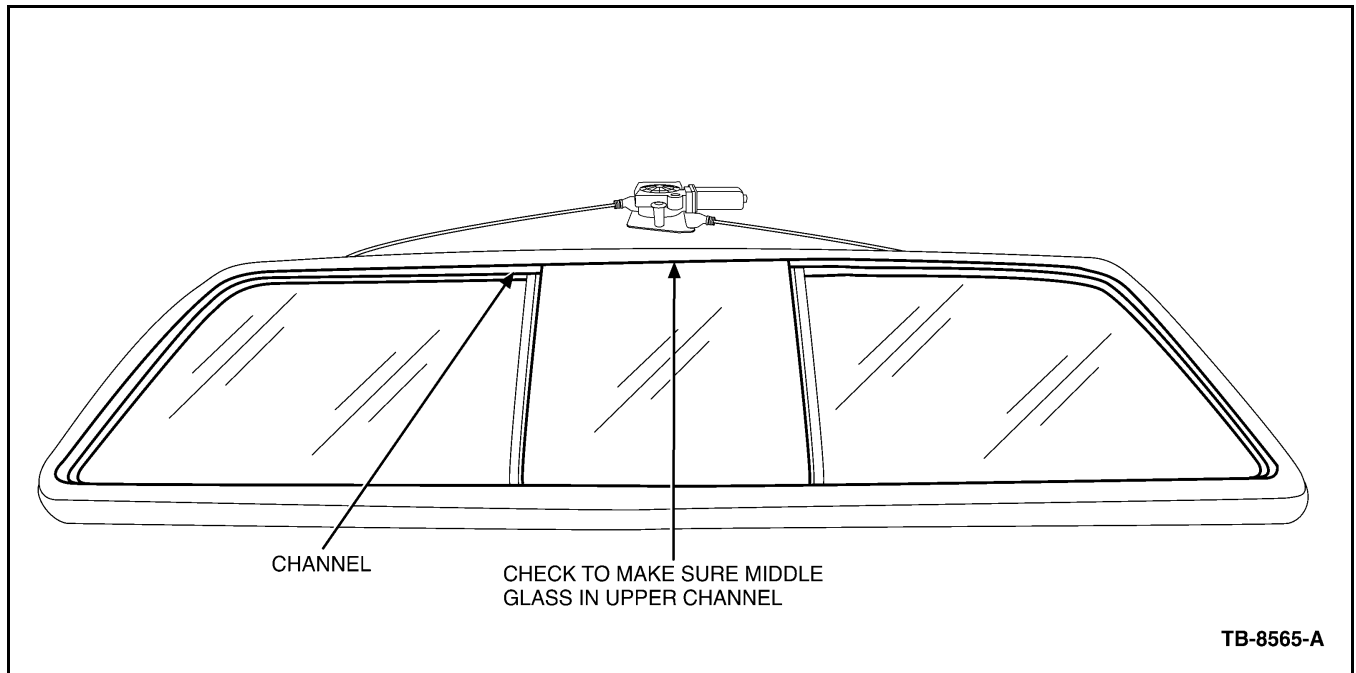

Figure 1 - Article 06-15-5

2. If Step 1 resolves the issue, return the vehicle back to customer after verifying the window functions properly. If it did not resolve the issue, proceed to Step 3.
3. Open the rear window approximately half way.
4. Refer to window removal procedure. (Refer to Workshop Manual (WSM), Section 501-11-24 and 501-11-25.)
5. Remove cable clips from sheet metal. (Refer to WSM, Section 501-11-28.)
6. Remove three (3) motor bracket attaching bolts. (Refer to WSM, Section 501-11-28.)

**NOTE:** The information in Technical Service Bulletins is intended for use by trained, professional technicians with the knowledge, tools, and equipment to do the job properly and safely. It informs these technicians of conditions that may occur on some vehicles, or provides information that could assist in proper vehicle service. The procedures should not be performed by "do-it-yourselfers". Do not assume that a condition described affects your car or truck. Contact a Ford, Lincoln, or Mercury dealership to determine whether the Bulletin applies to your vehicle. Warranty Policy and Extended Service Plan documentation determine Warranty and/or Extended Service Plan coverage unless stated otherwise in the TSB article. The information in this Technical Service Bulletin (TSB) was current at the time of printing. Ford Motor Company reserves the right to supersede this information with updates. The most recent information is available through Ford Motor Company's on-line technical resources.

## TSB 06-15-5 (Continued)

7. Disconnect motor wiring harness from vehicle body harness. (Refer to WSM, Section 501-11-29.)
8. Remove window assembly from vehicle window opening.
9. Pull outer rubber seal from window frame (Figure 2).

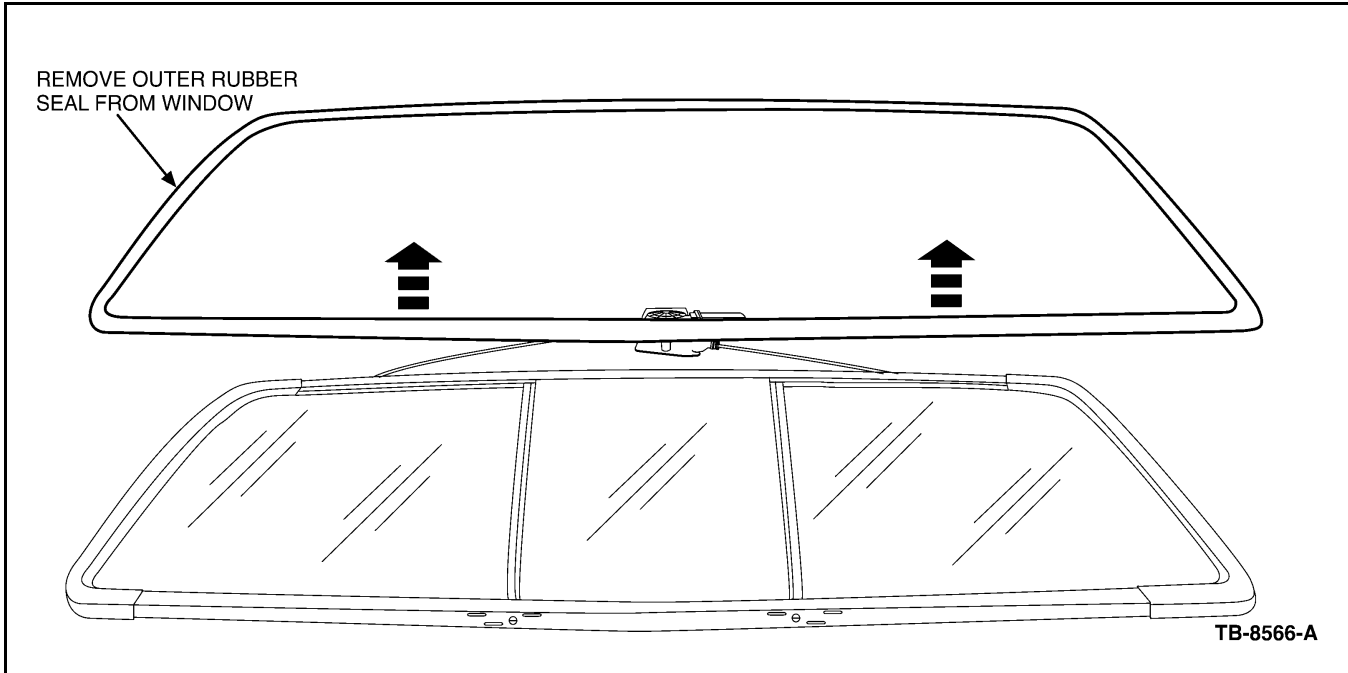

Figure 2 - Article 06-15-5

10. Locate two (2) screws in bottom of lower frame and remove them with a R1 square bit screw driver (Figure 3).

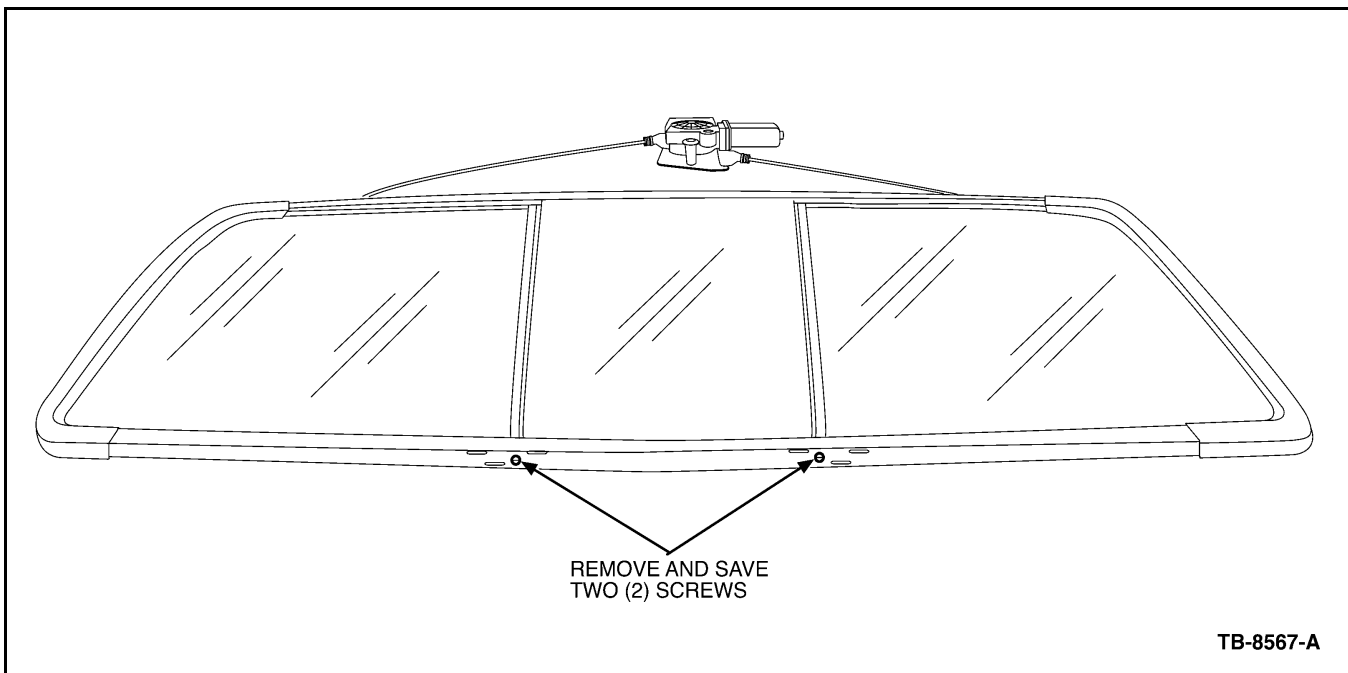

Figure 3 - Article 06-15-5

11. Pull driver and passenger side plastic vertical portion of window frame from upper and lower rails (Figure 4).

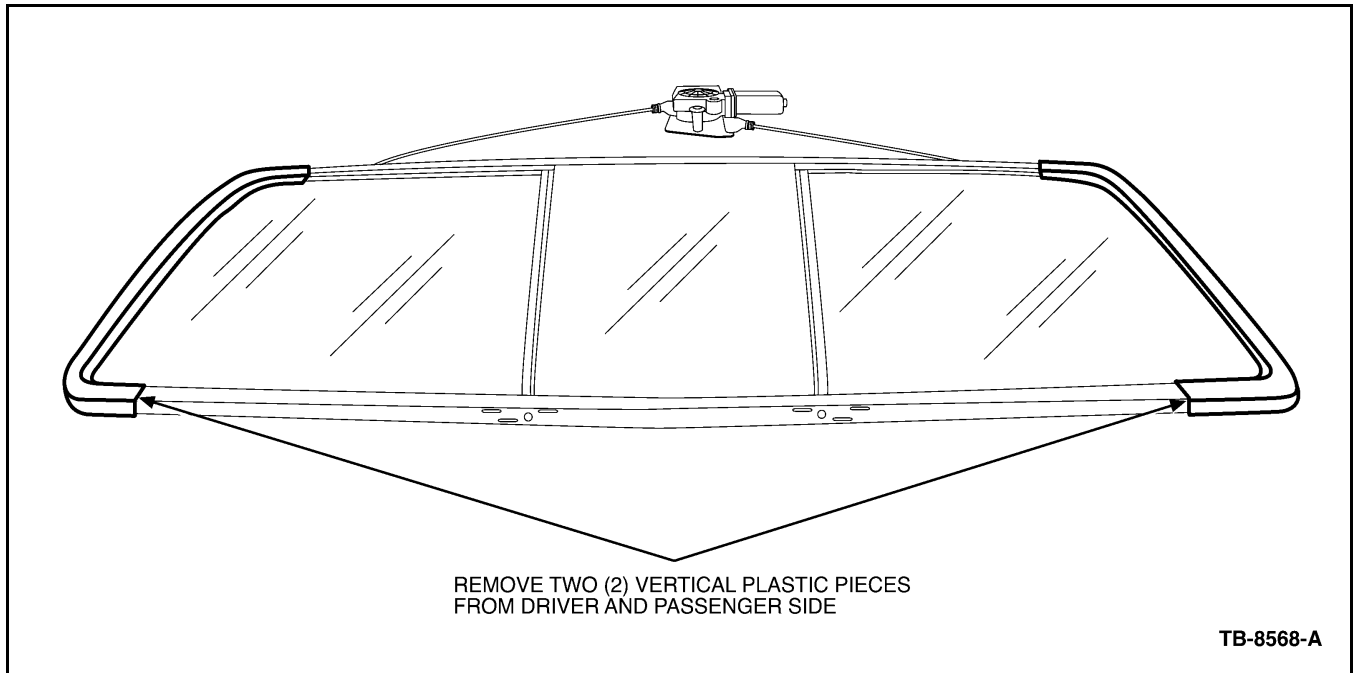

Figure 4 - Article 06-15-5

12. Insert screw driver into lower channel and hit with mallet to separate lower channel from the window assembly (Figure 5).

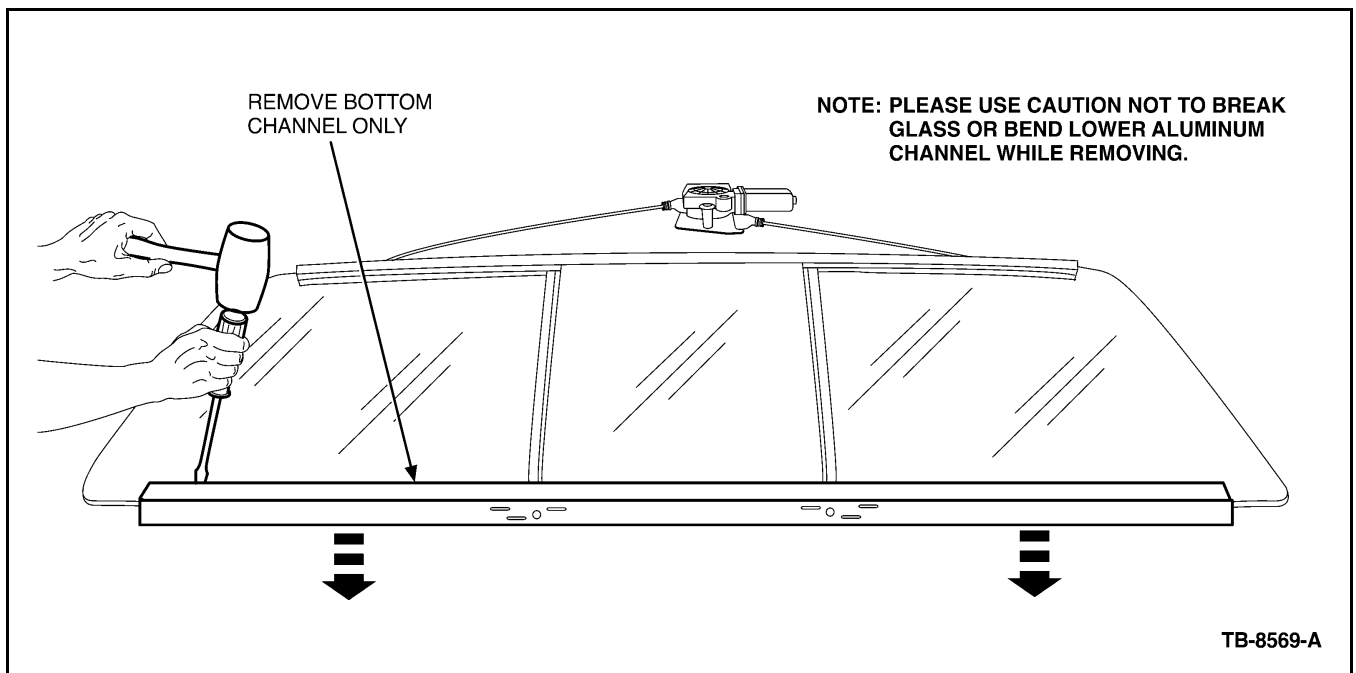

Figure 5 - Article 06-15-5

13. Inspect the lower rail and motor assembly for damage or loose center glass, while cycling the motor, cable, glass, and lower rail assembly.
14. If center glass is bonded to black carrier, proceed to Step 23, if not, proceed to Step 15.

## TSB 06-15-5 (Continued)

15. The preferred method is to re-bond the center glass to carrier, but center glass assembly is also available for service. Refer to Step 16 for re-bonding or refer to Step 23 for replacing center glass assembly.
16. Remove center glass from carrier and remove any remaining urethane.
17. Remove center glass seal from window and scrape cured urethane adhesive from center glass (Figures 6 and 7).

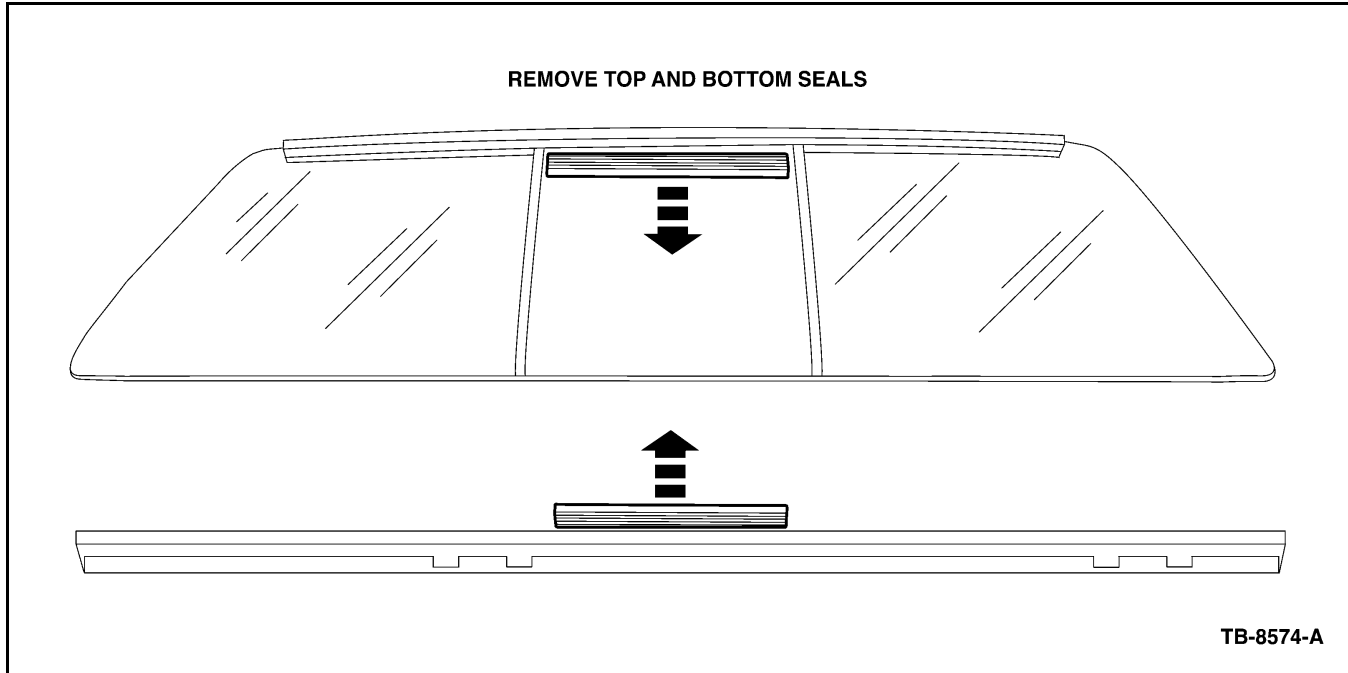

Figure 6 - Article 06-15-5

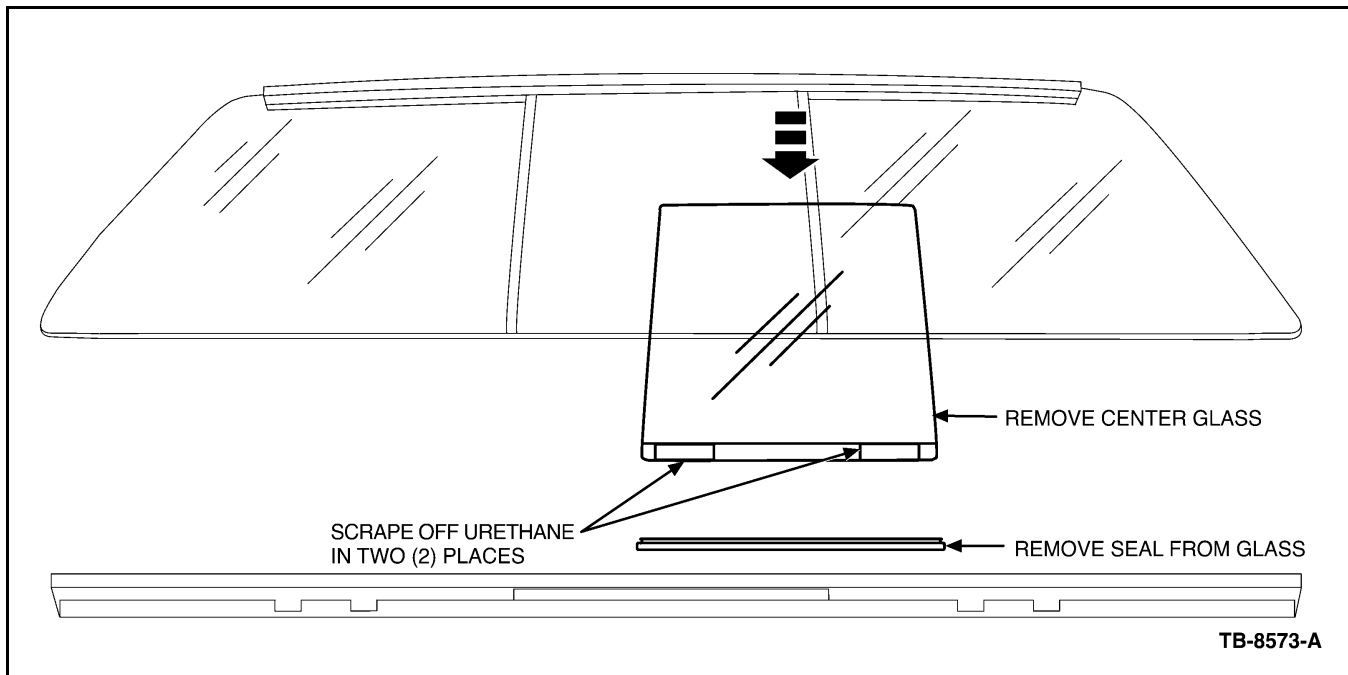

Figure 7 - Article 06-15-5

18. Apply a 2" x 3/16" (5 cm x 5 mm) bead of urethane adhesive in the carrier starting 1/2" (1.3 cm) inboard from notches in carrier (Figure 8).

## TSB 06-15-5 (Continued)

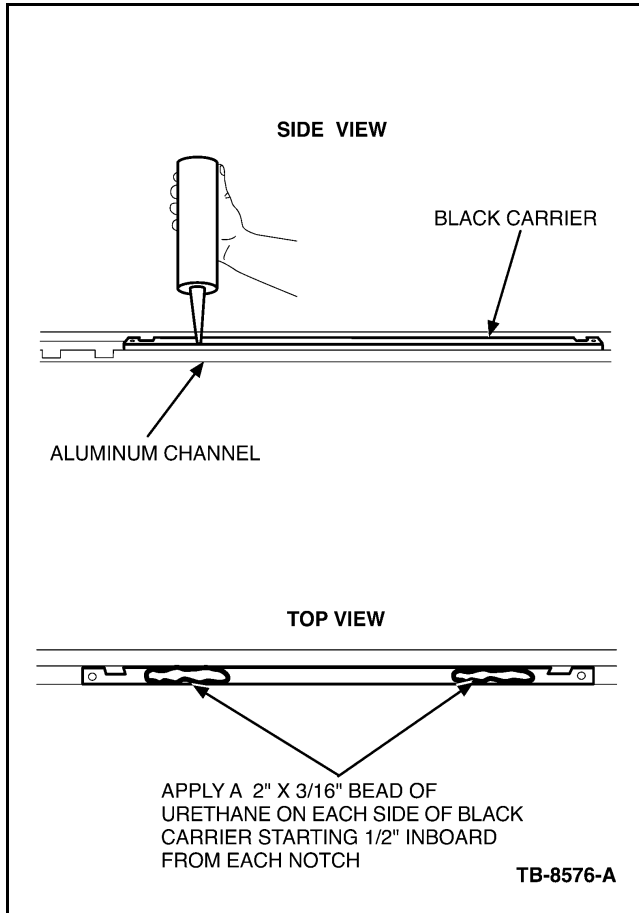

Figure 8 - Article 06-15-5

19. Cut 2" (5 cm) from center glass seal (Figure 9) and reapply seal to bottom of the center glass centering it from side to side (Figure 10).

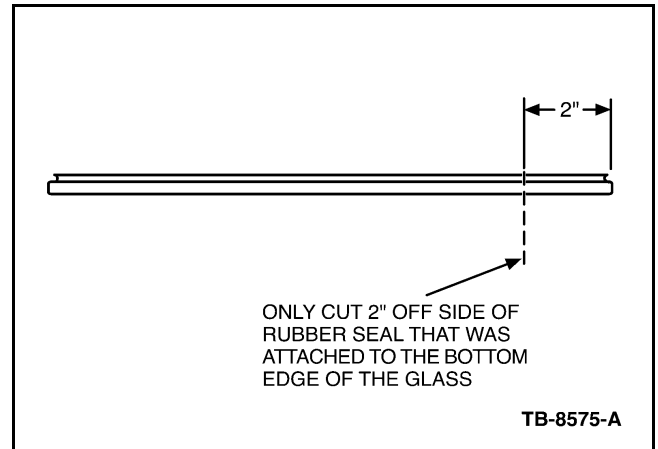

Figure 9 - Article 06-15-5

20. Center glass in carrier and push down into carrier until glass/seal bottoms out in carrier (Figure 10).

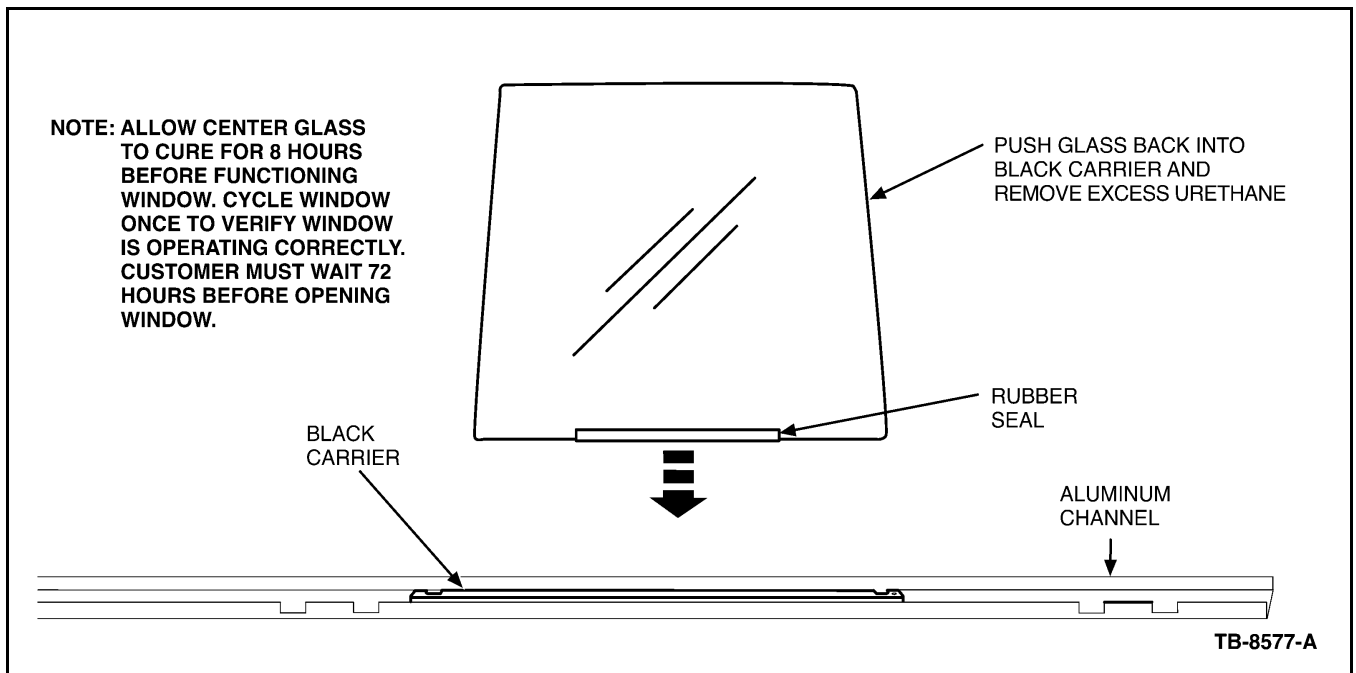

Figure 10 - Article 06-15-5

## TSB 06-15-5 (Continued)

21. Scrape away any excess urethane adhesive and function window once to verify it is operating correctly after urethane adhesive has cured for 8 hours. Customer must wait 72 hours prior to functioning the window to allowing the urethane adhesive to cure.
22. Proceed to Step 34.
23. Remove driver's side transition block from lower aluminum channel by prying loose with a screw driver (Figure 11).

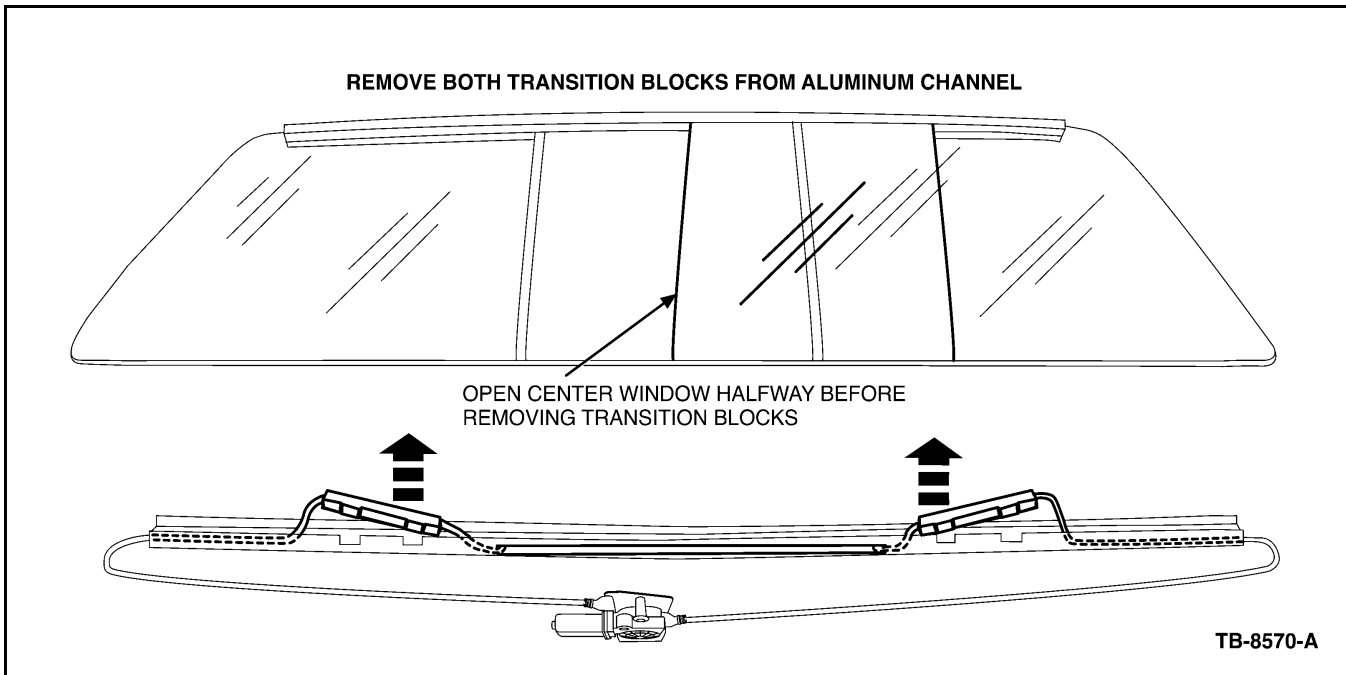

Figure 11 - Article 06-15-5

24. Remove passenger side transition block and cable cover from lower aluminum channel by prying loose with a screw driver (Figure 11).
25. Once cable assemblies are loose from aluminum channel, slide glass carrier towards driver's side end and out of aluminum channel (Figure 12).

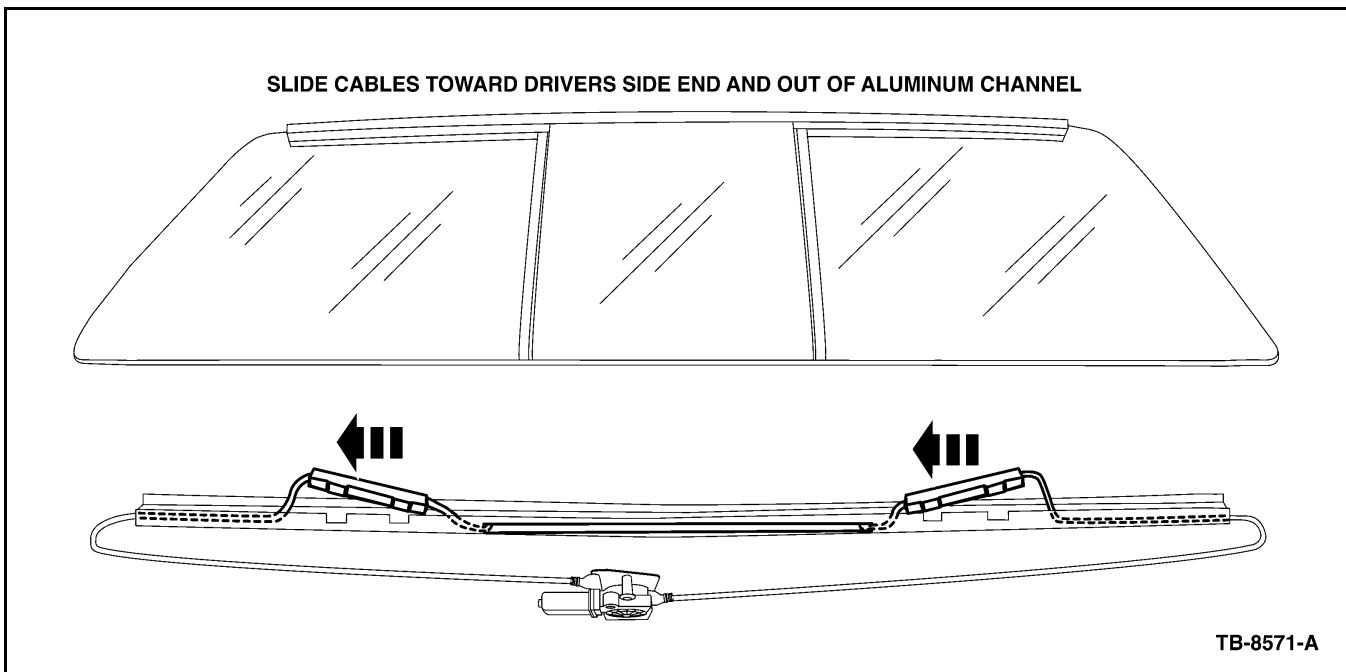

Figure 12 - Article 06-15-5

26. Remove cable ends from black carrier using access holes in the bottom of the carrier (Figure 13).

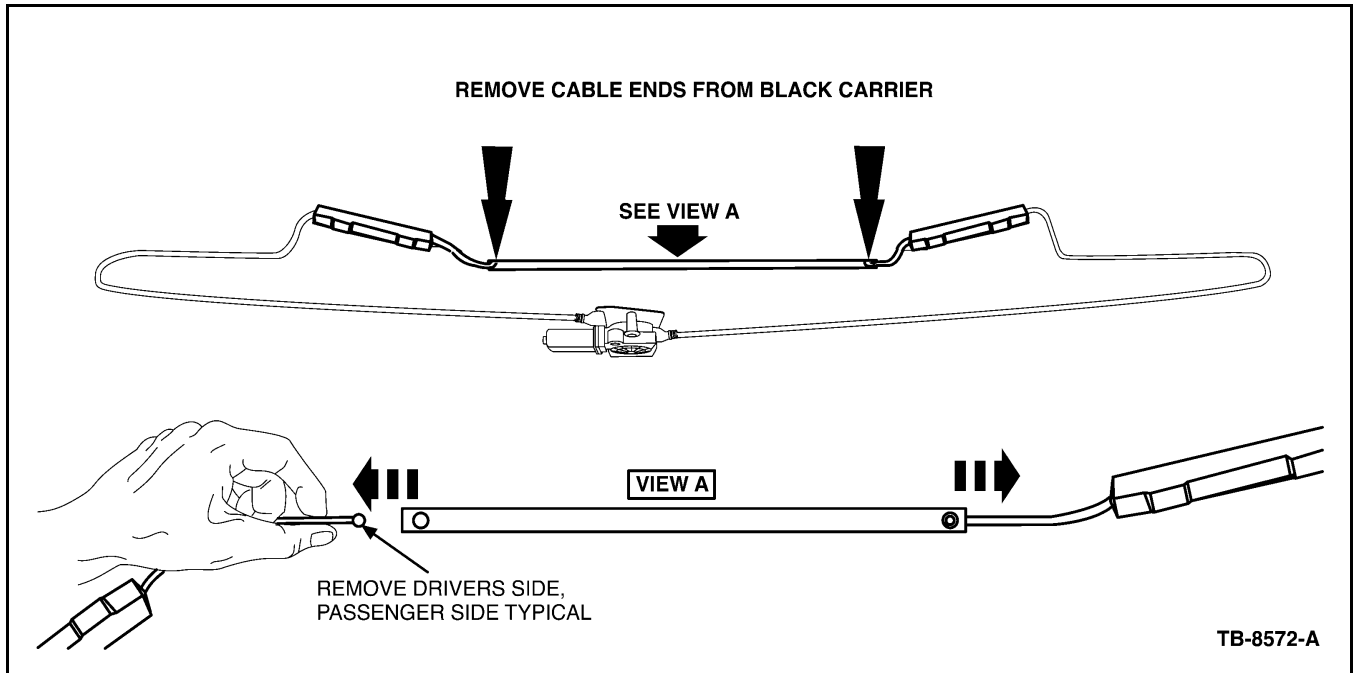

Figure 13 - Article 06-15-5

27. Discard carrier and glass.
28. Obtain new center glass assembly.
29. Attach cable ends to new center glass by inserting into end of black carrier and pushing downwards making sure the die cast end retains cable properly (Figure 13).
30. Slide new assembly into lower aluminum channel.
31. Pull cables tight and snap into correct location (reverse of Step 25).
32. Verify that assembly functions properly by cycling assembly.
33. Obtain motor, cable, lower channel, and center glass assembly or use updated assembly from Step 32.
34. Place motor, cable, lower channel, and center glass assembly on flat surface.
35. Verify two (2) outside fixed glass panels have rubber weather-strip on the edge and push into lower channel.
36. While pushing the window together the center glass should slide into the center of the plastic channel in the upper aluminum channel assembly.
37. Align vertical divider post in lower channel and tap entire window assembly together using a mallet.
38. Locate screws and reinstall them into the vertical divider post through the lower channel.
39. Reinstall weather seals. (Figure 6)
40. Cycle window to verify window functions properly (only windows which did not have urethane adhesive repair).
41. Reinstall window into opening. (Refer to WSM, Section 501-11-26.)
42. Attach motor bracket back on the vehicle. (Refer to WSM, Section 501-11-28.)
43. Attach window cable clips back into the vehicle. (Refer to WSM, Section 501-11-28.)
44. Connect motor wiring connector back to vehicle body harness.
45. Cycle window again to verify window is functioning properly.

| PART NUMBER     | PART NAME                     |
|-----------------|-------------------------------|
| 6W7Z-19B508-A   | Urethane Adhesive             |
| 6C3Z-2842006-B  | Rear Window Center Glass Assy |
| 4C3Z-1523394-AA | Motor and Cable Assy          |

## TSB 06-15-5 (Continued)

**WARRANTY STATUS:** Eligible Under Provisions Of  
New Vehicle Limited  
Warranty Coverage

| OPERATION | DESCRIPTION   | TIME     |
|-----------|---|----------|
| 061505A   | 2004-2007 F-Super Duty<br>250/350 Super Cab:<br>Inspect And Reposition<br>The Upper Run Channel,<br>Verify Repair (Do Not Use<br>With 42006A, 42006B,<br>29314A, 13208A)  | 0.2 Hr.  |
| 061505B   | 2004-2007 F-Super Duty<br>250/350 Super Cab:<br>Inspect The Upper Run<br>Channel, Remove Rear<br>Window Following TSB<br>Procedure, Replace The<br>Center Glass And Or The<br>Window Regulator<br>Assembly, Verify Repair<br>(Do Not Use With 42006A,<br>42006B, 29314A, 13208A)            | 1.4 Hrs. |
| 061505C   | 2004-2007 F-Super Duty<br>250/350 Super Cab:<br>Inspect The Upper Run<br>Channel, Remove Rear<br>Window Following TSB<br>Procedure, Re-Bond The<br>Center Glass And Or<br>Replace The Window<br>Regulator Assembly, Verify<br>Repair (Do Not Use With<br>42006A, 42006B, 29314A,<br>13208A) | 1.5 Hrs. |

|         |   |          |
|---------|---|----------|
| 061505D | 2004-2007 F-Super Duty<br>250/350 Crew Cab: Inspect<br>And Reposition The Upper<br>Run Channel, Verify<br>Repair (Do Not Use With<br>42006A, 42006B, 29314A,<br>13208A)   | 0.2 Hr.  |
| 061505E | 2004-2007 F-Super Duty<br>250/350 Crew Cab: Inspect<br>The Upper Run Channel,<br>Remove Rear Window<br>Following TSB Procedure,<br>Replace The Center Glass<br>And Or The Window<br>Regulator Assembly, Verify<br>Repair (Do Not Use With<br>42006A, 42006B, 29314A,<br>13208A)         | 1.5 Hrs. |
| 061505F | 2004-2007 F-Super Duty<br>250/350 Crew Cab: Inspect<br>The Upper Run Channel,<br>Remove Rear Window<br>Following TSB Procedure,<br>Re-Bond The Center Glass<br>And Or Replace The<br>Window Regulator<br>Assembly, Verify Repair<br>(Do Not Use With 42006A,<br>42006B, 29314A, 13208A) | 1.6 Hrs. |

### DEALER CODING

BASIC PART NO.  
2842006

CONDITION  
CODE  
42