

1994 Chevrolet C3500 PICKUP

Submodel: | Engine Type: V8 | Liters: 6.5

Fuel Delivery: FI | Fuel: DIESEL

Carbureted Gasoline Engines

FILTER IN CARBURETOR

Fig. 1: In-carburetor fuel filter

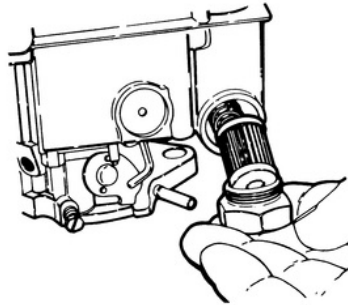

The fuel filter should be serviced at the interval given on the Maintenance Interval chart. Two types of fuel filters are used, a bronze type and a paper element type. Filter replacement should be attempted only when the engine is cold. Additionally, it is a good idea to place some absorbent rags under the fuel fittings to catch the gasoline which will spill out when the lines are loosened.

1. Disengage the fuel line connection at the intake fuel filter nut. Plug the opening to prevent loss of fuel.
2. Remove the intake fuel filter nut from the carburetor with a 1 in. open end wrench (or adjustable wrench).
3. Remove the filter element and spring.
4. Check the element for restrictions by blowing on the cone end. Air should pass freely.
5. Clean or replace the element, as necessary.

To install:

6. Install the element spring, then the filter element in the carburetor. Bronze filters should have the small section of the cone facing out.
7. Install a new gasket on the intake fuel nut. Install the nut in the carburetor body and tighten securely.
8. Install the fuel line and tighten the connector.

INLINE FILTER

Some trucks may have an inline filter. This is a can-shaped device located in the fuel line between the pump and the carburetor. It may be made of either plastic or metal. To replace the filter:

1. Place some absorbent rags under the filter. Remember, it will be full of gasoline when removed.
2. Use a pair of pliers to expand the clamp on one end of the filter, then slide the clamp down past the point to which the filter pipe extends in the rubber hose. Do the same with the other clamp.
3. Gently twist and pull the hoses free of the filter pipes. Remove and discard the old filter.

NOTE: Most replacement filters come with new hoses that should be installed with a new filter.

4. Install the new filter into the hoses, slide the clamps back into place, and check for leaks with the engine idling.

Fuel Injected Gasoline Engines

EXCEPT CARTRIDGE TYPE

Fig. 2: Fuel filter location mounting and lines

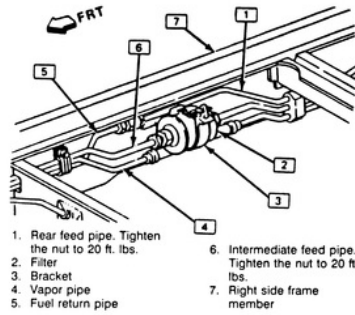
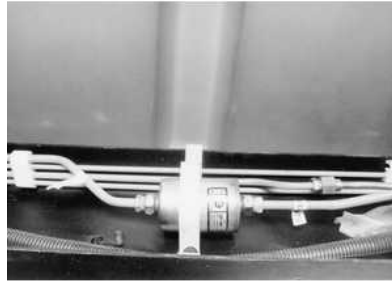

Fig. 3: The fuel filter is found along the frame rail



The inline filter on the fuel injected models is found along the frame rail.

1. Properly relieve the fuel system pressure.

CAUTION

The 220 TBI unit used on the V6 and V8 engines contains a constant bleed feature in the pressure regulator that relieves pressure any time the engine is turned off. Therefore, no special relief procedure is required, however, a small amount of fuel may be released when the fuel line is disconnected. To reduce the chance of personal injury, cover the fuel line with cloth to collect the fuel and then place the cloth in an approved container.

2. Disconnect the fuel lines.
3. Remove the fuel filter from the retainer or mounting bolt.

To install:

4. Install the filter and tighten the bolt to 12 ft. lbs. (16 Nm). Connect the fuel lines and tighten the nuts to 20 ft. lbs. (26 Nm).
5. Road test the truck and check for any leaks.

NOTE: The filter has an arrow (fuel flow direction) on the side of the case, be sure to install it correctly in the system, the with arrow facing away from the fuel tank.

Fig. 4: Using two flare nut wrenches, disconnect the fuel lines

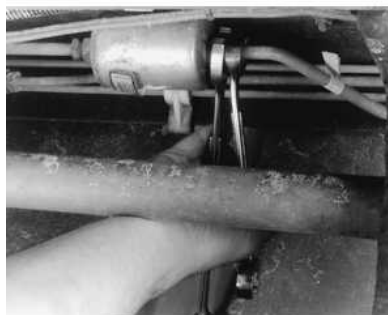

CARTRIDGE TYPE

1. Properly relieve the fuel system pressure.
2. Disconnect the negative battery cable.
3. turn the filter housing counterclockwise and allow the fuel to drain into a suitable container.
4. Remove the filter housing and gasket from the base.
5. Remove the fuel filter cartridge.
6. Inspect the filter housing for signs of corrosion or damage, replace as necessary.

To install:

7. Apply a few drops of clean engine oil to the new housing gasket and install the gasket.
8. Install a new filter cartridge and place the filter housing into position.
9. Tighten the housing by turning it clockwise until the gasket seats, then tighten the housing an additional $\frac{3}{4}$ turn.
10. Connect the negative battery cable.
11. Start the engine and check for fuel leaks.
12. Repair as necessary.

Fig 5: The cartridge type fuel filter is located along the frame rail

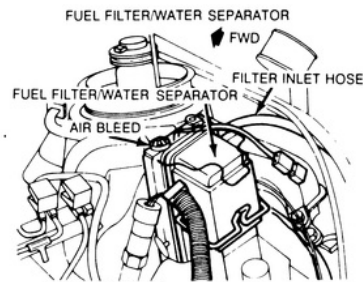

Diesel Engines

6.2L ENGINE

The fuel/water separator is usually located on the header assembly.

Fig. 6: Exploded view of the fuel filter — 6.2L engines

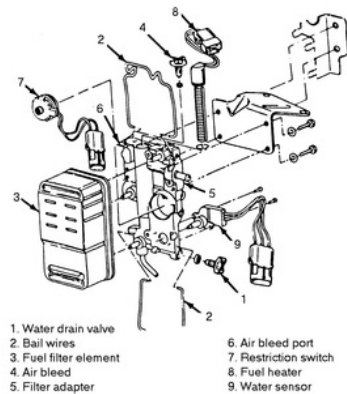
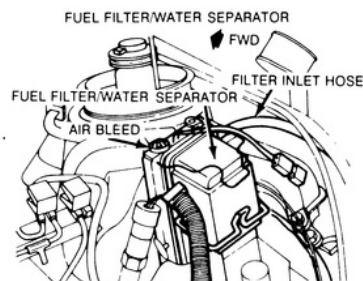

Fig. 7: Fuel filter/water separator — 6.2L engines



1. Drain the fuel from the fuel filter by opening both the air bleed and the water drain valve allowing the fuel to drain out into an appropriate container.
2. Remove the fuel tank cap to release any pressure or vacuum in the tank.
3. Unstrap both bail wires with a screwdriver and remove the filter.

To install:

4. Before installing the new filter, insure that both filter mounting plate fittings are clear of dirt.
5. Install the new filter, snap into place with the bail wires.
6. Close the water drain valve and open the air bleed valve. Connect a $\frac{1}{8}$ in. (3mm) I.D. hose to the air bleed port and place the other end into a suitable container.
7. Disconnect the fuel injection pump shut off solenoid wire.
8. Crank the engine for 10–15 seconds, then wait one minute for the starter motor to cool. Repeat until clear fuel is observed coming from the air bleed.

NOTE: If the engine is to be cranked, or starting attempted with the air cleaner removed, care must be taken to prevent dirt from being pulled into the air inlet manifold which could result in engine damage.

9. Close the air bleed valve, reconnect the injection pump solenoid wire and replace the fuel tank cap.
10. Start the engine, allow it to idle for 5 minutes and check the fuel filter for leaks.

6.5L ENGINE

1. Remove the fuel tank cap to release any pressure or vacuum in the tank.
2. If equipped, remove the upper intake manifold cover.
3. Open the air bleed valve on top of the filter assembly.
4. Spin off the element nut at the top of the filter — it looks like a large knurled knob.
5. Lift the filter element out of the header assembly.

To install:

6. Clean the mating surfaces on the header assembly and the filter. Align the widest key slot in the element cap with that in the header assembly, push the element down until the two surfaces make contact, then tighten the nut by hand.

Fig. 8: Exploded view of the fuel filter — 6.5L engines

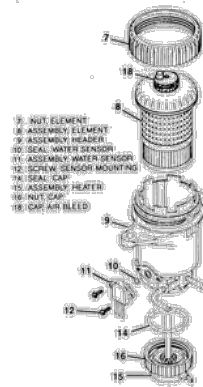

7. Open the air bleed valve on top of the filter assembly. Connect a hose to the bleeder valve and insert the other end into a suitable glass container.
8. Disconnect the fuel injection pump shut-down solenoid wire or the FUEL SOL relay center fuse (whichever applies to your vehicle, then crank the engine in 10–15 second intervals until clear, clean fuel is coming out of the hose.

NOTE: Wait about one minute between cranking intervals!

9. Remove the hose and close the bleeder valve.
10. Connect the shut-down solenoid wire or fuse and install the fuel cap. Start the engine and allow it to idle for a few minutes. Check for leaks.