

# RACE TEAM TURBOS

## Sizes and Prices

# TRACK MASTER

V-Band compressor outlet with surge control BD compressor cover with enhanced pressure ratio

Turbos upgraded with

- 6 pad thrust bearings replace stock 3 pad
- Grooved axial bearings
- Assembly balancing

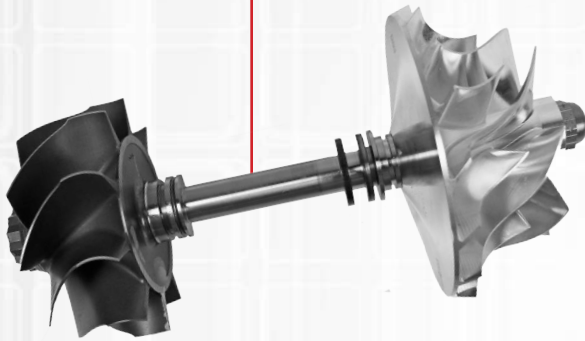

Compressor wheels available in:

- Hip'd Cast
- FMW and Billet

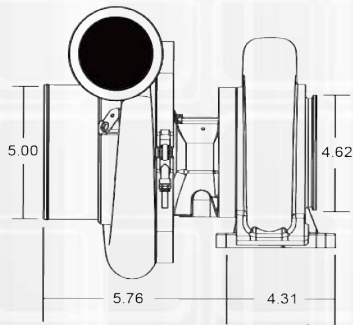
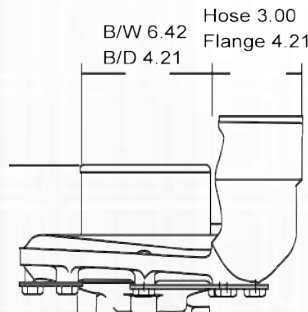
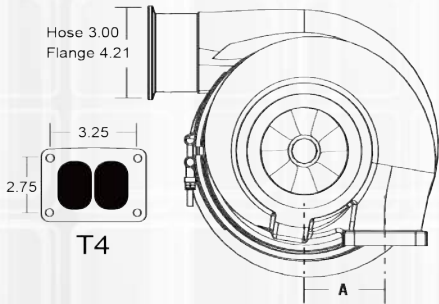

Full marmon exhaust flange



Size your turbo  
DieselTurboMatch.com



1-800-887-5030

www.bddieselperformance.com



### S400SX3 83 Turbine

LBS/MIN	Comp Wheel Inducer	Price	Turbine Wheel Inducer	A/R	Flange
85	67.5 mm	\$1016	83.4 mm/ 74 mm	0.90 / 1.00 1.10 / 1.25	T4
95	72.0 mm				
105	74.6 mm				

### S400SX3 87 Turbine

LBS/MIN	Comp Wheel Inducer	Price	Turbine Wheel Inducer	A/R	Flange
106	76.0 mm	\$1395	87.3 mm/ 83 mm	0.90 / 1.00 1.10 / 1.25	T4
120	80.3 mm				
127	82.2 mm				
136	86.0 mm				
140	88.0 mm				

### OPTIONS

Compressor Housing V-Band Outlet

Lucas 2.6 Inducer

Tach Sensor Port

# RACE TEAM TURBOS

## Sizes and Prices

# TRACK MASTER

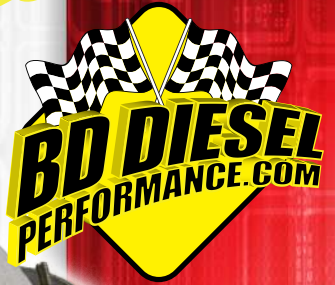

S400SX4 96 Turbine					
LBS/MIN	Comp Wheel Inducer	Price	Turbine Wheel Inducer	A/R	Flange
102	71 mm	\$750	96.0 mm/ 88.0 mm	1.32	T6
105	75 mm	\$750			
120	80 mm	\$1000			
127	82 mm	\$1125			
136	86 mm	-			
140	88 mm	-			

### OPTIONS

- Compressor Housing V-Band Outlet
- Lucas 2.6 Inducers
- Tach Sensor Port

DieselTurboMatch.com

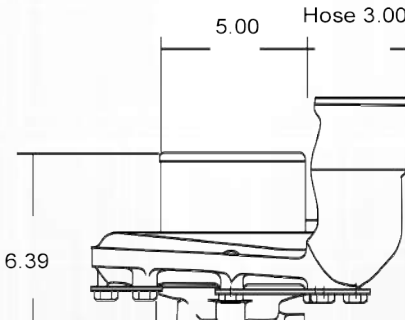
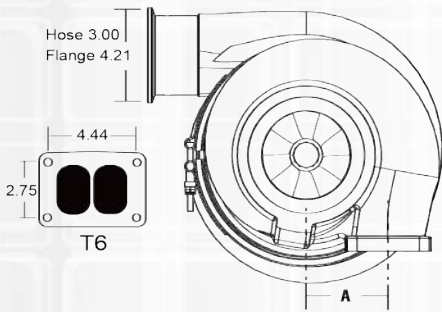

Full marmon exhaust flange



Hip'd Cast

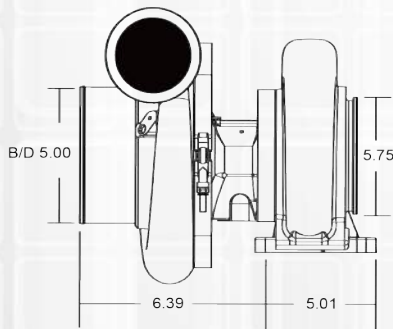
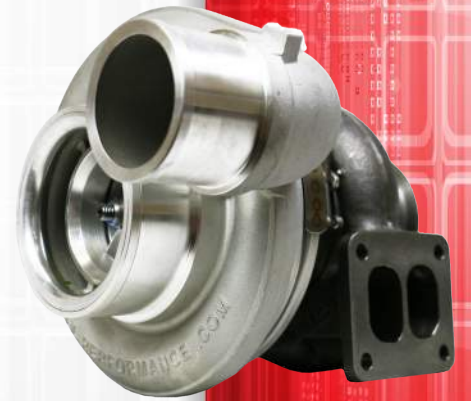

### PART NUMBER CONFIGURATION

SERIES	COMPRESSOR GROUP				TURBINE GROUP		
	COMPRESSOR WHEEL SIZE (2-digit)	B - BILLET C - CAST	COMP HSG OUTLET 1 - Straight 9 - 90 Degree F - V-Band Flanged	OPTION (CLASS) 00 - None 26 - 2.6 Class 28 - 2.8 Class L6 - Lucas 2.6 L3 - Lucas 3.0	TURBINE WHEEL SIZE (2-digit)	FLANGE MOUNT 3 - T3 4 - T4 6 - T6	AR RATIO (3-digit)

Part Number Example:

**S4 74 B F 00 - 87 4 110**

FMW and Billet

Part Number Examples using 120 lbs/min turbo configuration:

S400 series, 80.3mm (80) compressor wheel, billet wheel, flanged straight outlet, no class option, 87.3mm (87) turbine wheel, T4 Mount, 1.10 AR

**S480BF00-874110**

Check on availability and compatibility of components.

