

SECTION 303-01C Engine — 6.0L Diesel

CONTENTS

PAGE

IN-VEHICLE REPAIR

Intake Manifold	303-01C-2
-----------------------	-----------

IN-VEHICLE REPAIR

Intake Manifold

Material

Item	Specification
Motorcraft Premium Gold Engine Coolant VC-7-A (in California, Oregon and New Mexico VC-7-B, in Canada CVC-7-A)	WSS-M97B51-A1

Removal

All vehicles

1. Remove the auxiliary battery. For additional information, refer to Section 414-01.
2. Remove the cooling fan stator — 6.0L diesel engine. For additional information, refer to Section 303-03.
3. Remove the degas bottle. For additional information, refer to Section 303-03.
4. Remove the upper radiator hose.

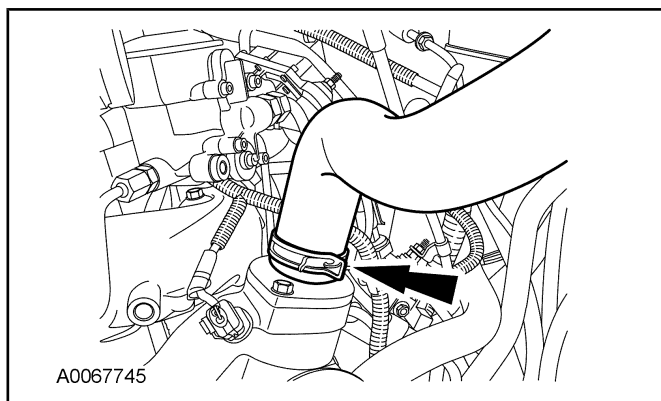

5. **NOTE:** Engine side shown, charge air cooler side similar.

Remove the turbocharger-to-charge air cooler (CAC) duct.

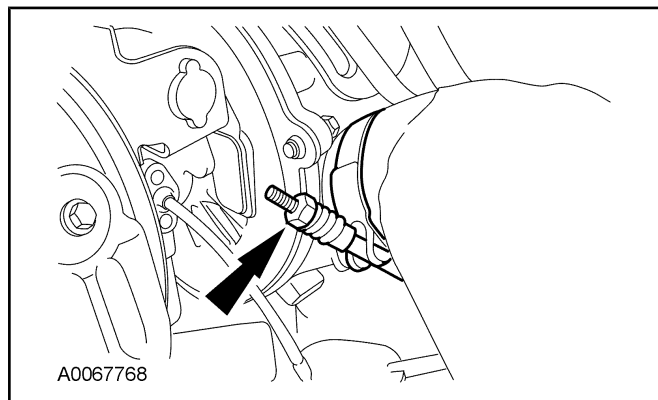

Vehicles with dual generators

6. Remove the accessory drive belt.

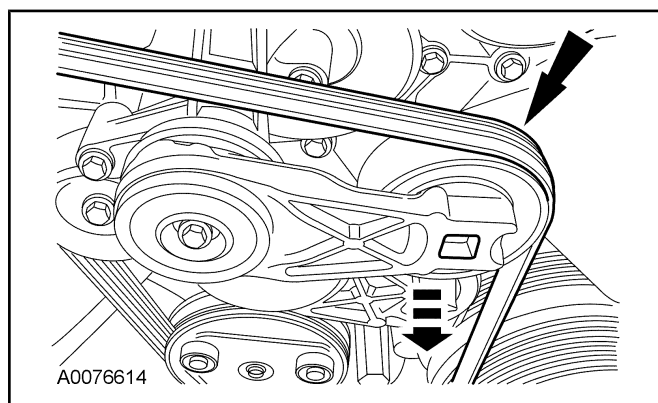

7. Remove the bolt and the accessory drive belt tensioner.

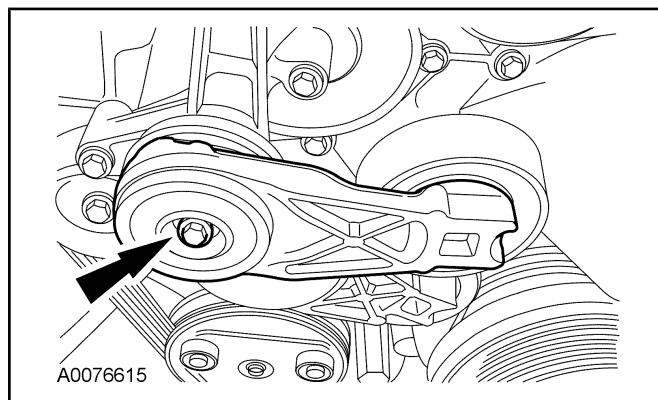

8. Remove the accessory drive belt.

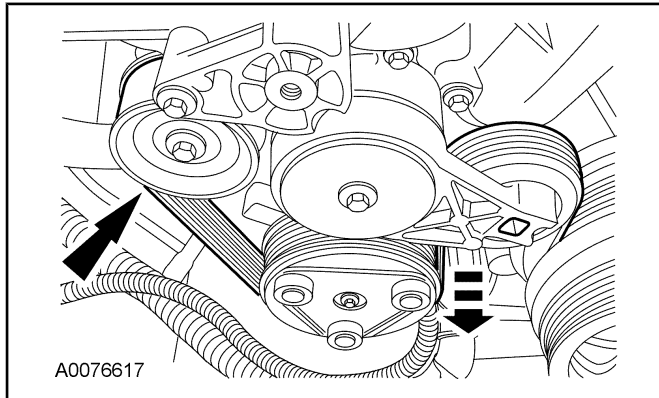
IN-VEHICLE REPAIR(Continued)

9. Remove the bolts, bracket and accessory drive belt idler pulley.

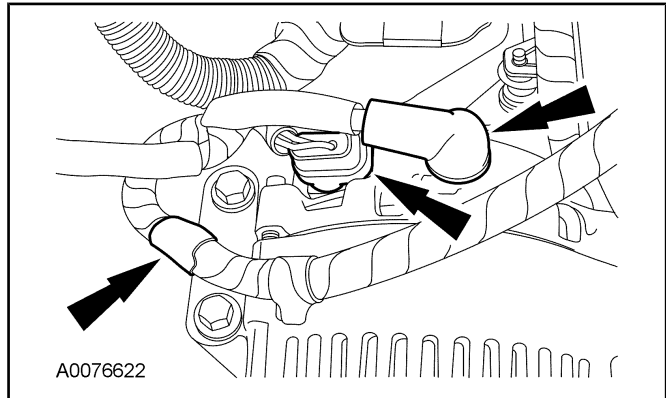

12. Remove the bolts and the generator with mounting bracket.

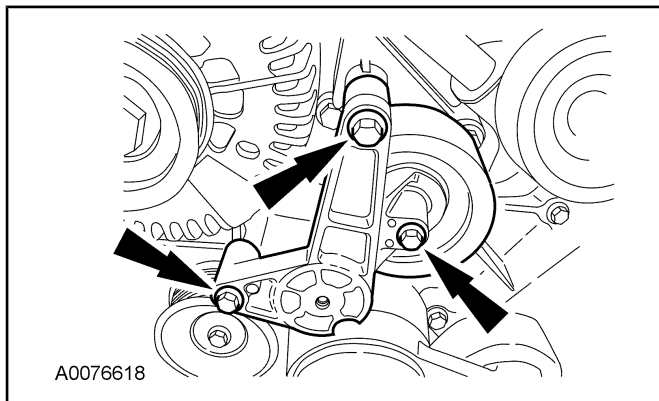

10. Remove the bolts and the accessory drive belt tensioner.

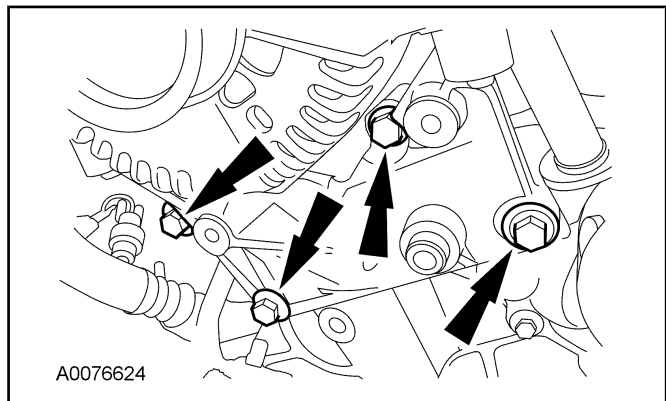
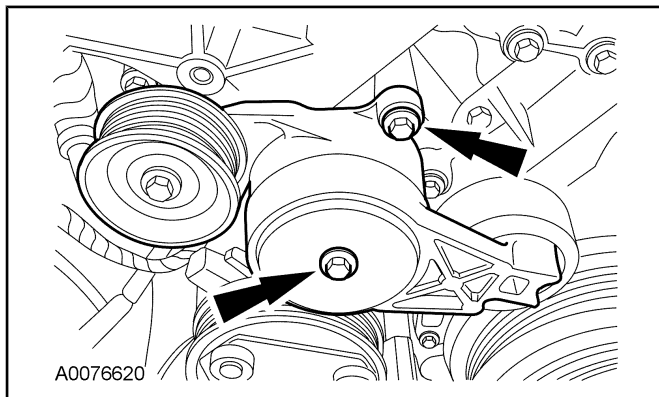
**Vehicles with single generator**

11. Disconnect the wire retainer, generator electrical connector and B+ wire.

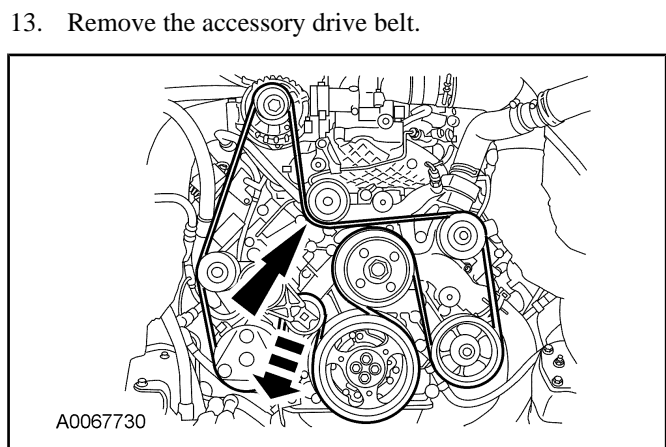

13. Remove the accessory drive belt.

All vehicles

14. Position the boot back and disconnect the generator B+ wire and electrical connector.

IN-VEHICLE REPAIR(Continued)

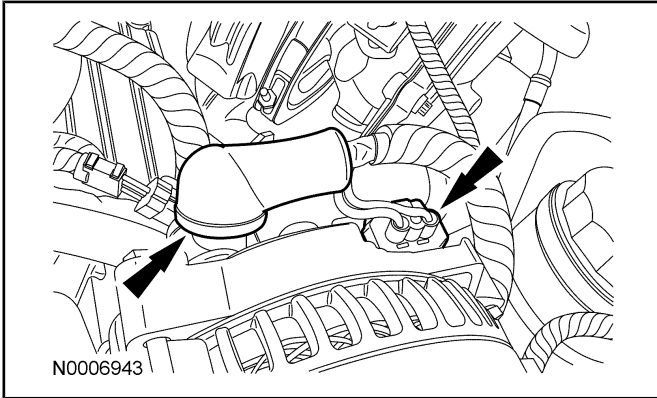

15. Remove the three bolts and the generator.

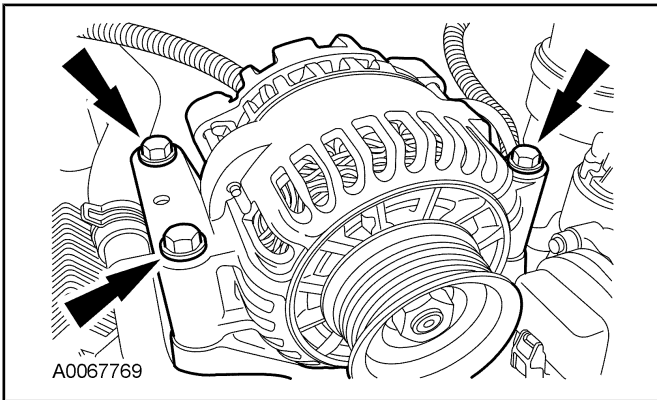

16. Remove the turbocharger and the turbocharger pedestal. For additional information, refer to Section 303-04D.

17. **NOTE:** Engine side shown, CAC side similar.

Loosen the clamps and remove the CAC duct.

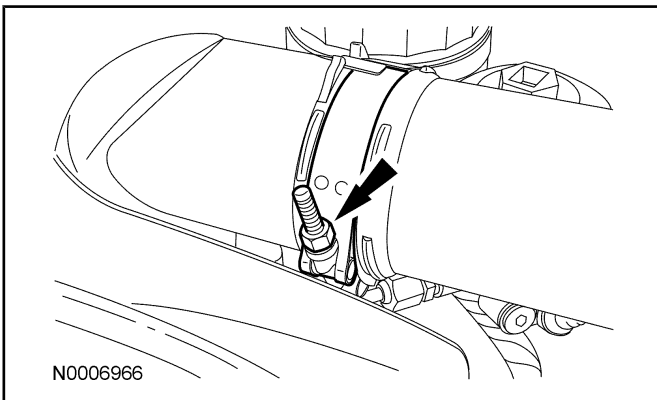

18. Remove the bolts and position the heater hose tube aside.
- Remove and discard the O-ring.

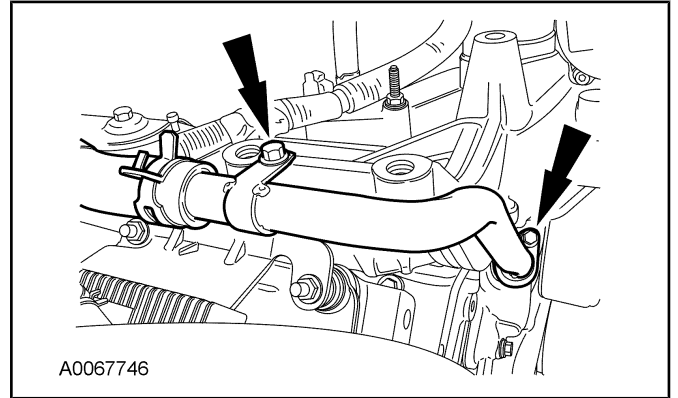

19. Disconnect the manifold absolute pressure (MAP) sensor hose.

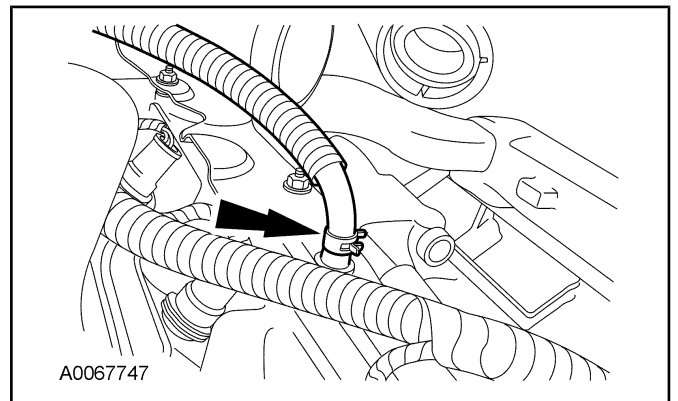

20. Disconnect the engine coolant vent hose.

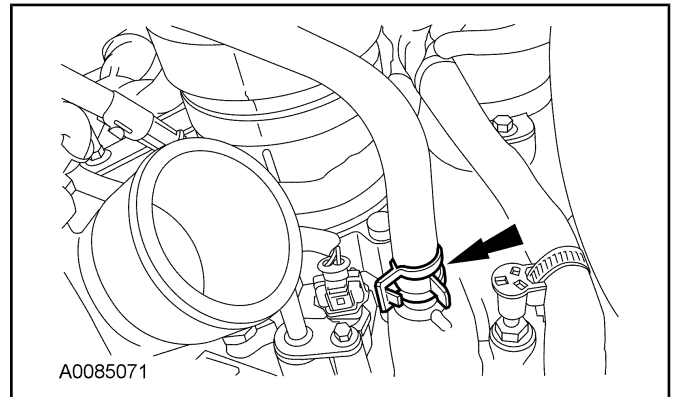

21. Remove the fuel injector control module. For additional information, refer to Section 303-14B.
22. If equipped with a heat shield bracket, remove the retaining nuts from the heat shield bracket.
- Disconnect the ground wire from the stud.

IN-VEHICLE REPAIR(Continued)

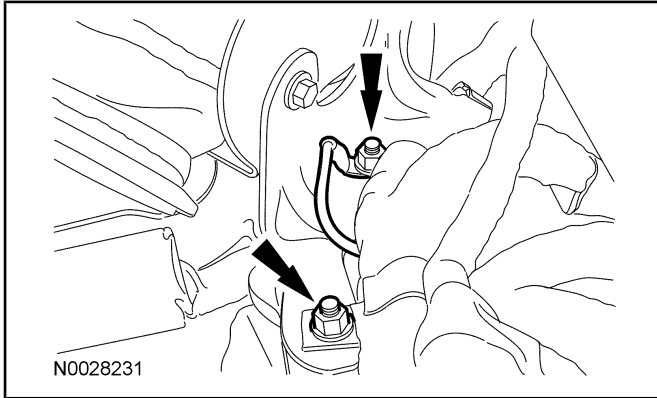

23. If equipped with a heat shield bracket, disconnect the wiring retainer from the heat shield bracket.

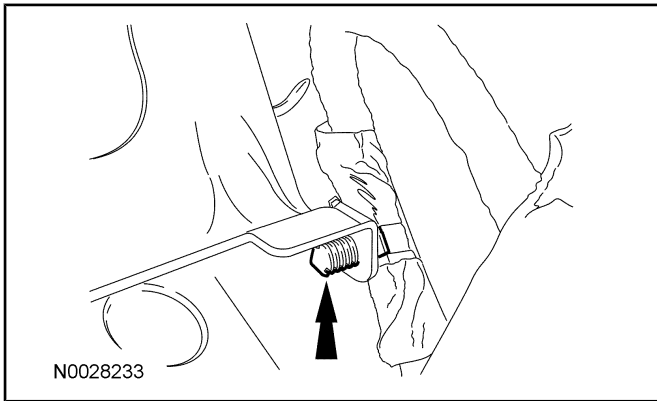

24. If equipped with a heat shield bracket, remove the bolts and heat shield bracket.

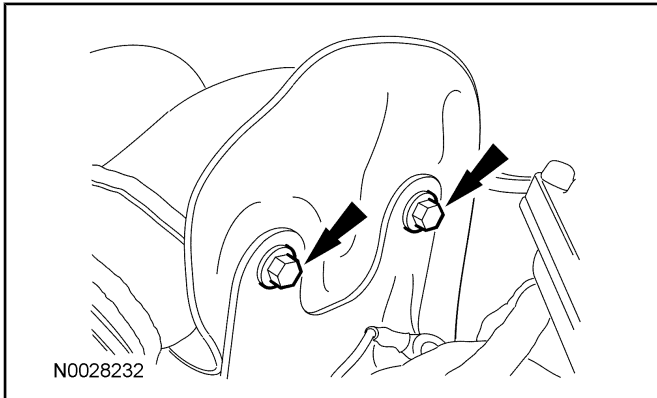

25. **NOTE:** Early build shown, late build similar.

Remove the top two bolts from the injector pressure regulator (IPR) heat shield.

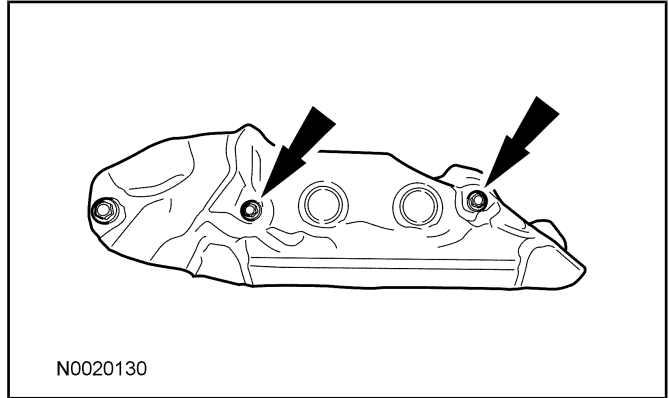

26. Position back the heat insulating wrap. Disconnect the wiring retainer and injector pressure regulator valve electrical connectors.

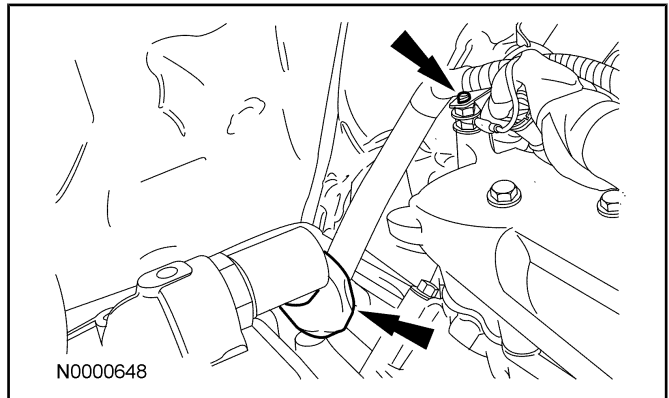

27. Disconnect the exhaust gas recirculation (EGR) valve electrical connector.

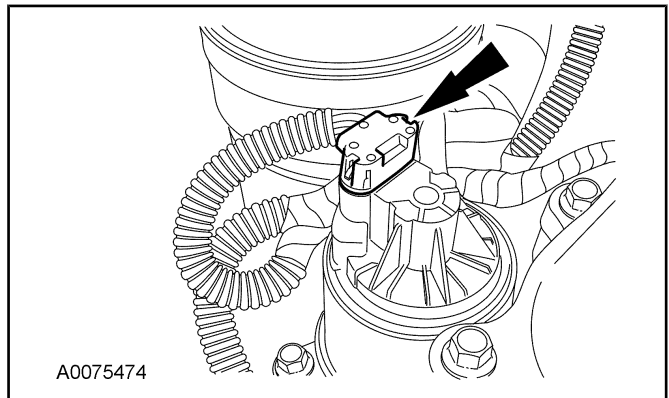

28. Disconnect the engine oil pressure (EOP) sensor electrical connector.

IN-VEHICLE REPAIR(Continued)

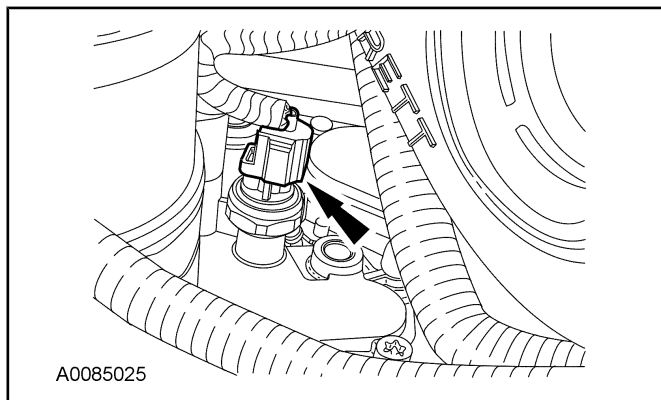

29. Disconnect the engine oil temperature (EOT) sensor electrical connector.

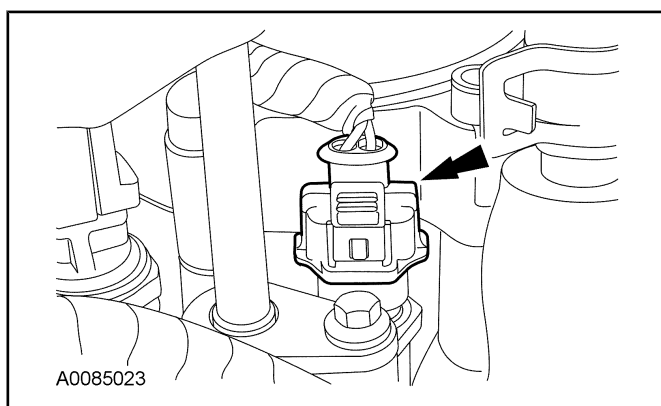

30. Disconnect the pin-type retainer and engine coolant temperature (ECT) sensor.

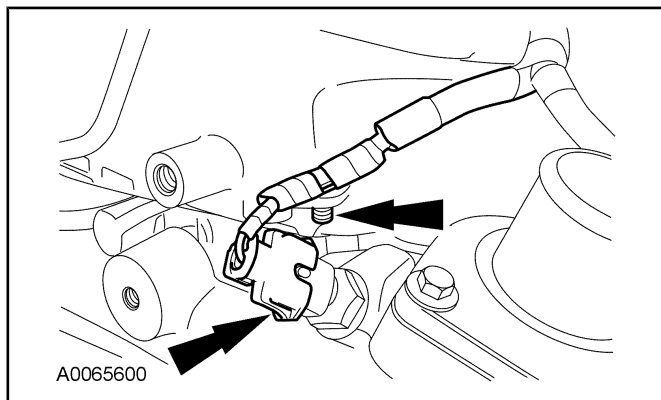

31. Disconnect the intake air temperature (IAT2) sensor electrical connector.

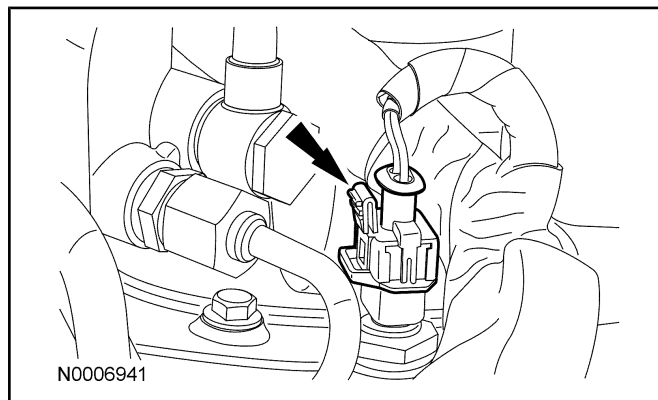

Early build vehicles

32. Disconnect the exhaust pressure (EP) sensor electrical connector.

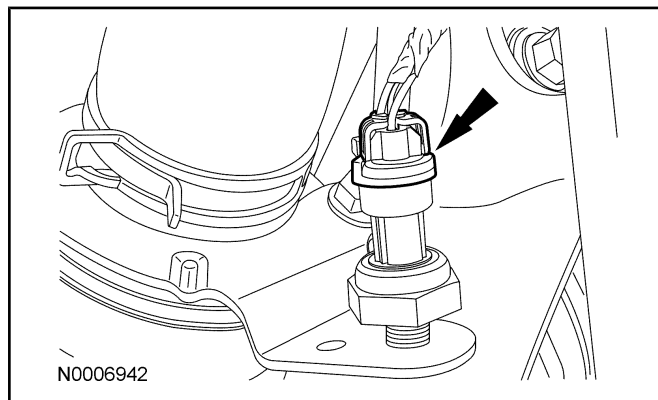

All vehicles

33. **NOTE:** Left side shown, right side similar.

Disconnect the eight fuel injectors electrical connectors. Remove the nut and the fuel injector wiring harness.

IN-VEHICLE REPAIR(Continued)

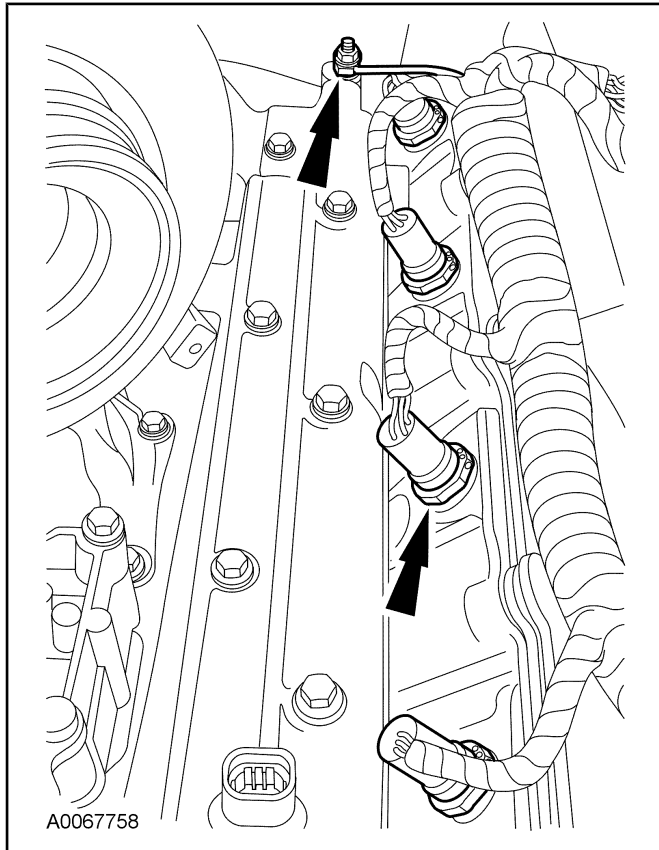

34. **NOTE:** It is necessary to remove the fuel filter and drain the housing.

Disconnect the fuel tube fittings.

- Remove and discard the sealing washers.

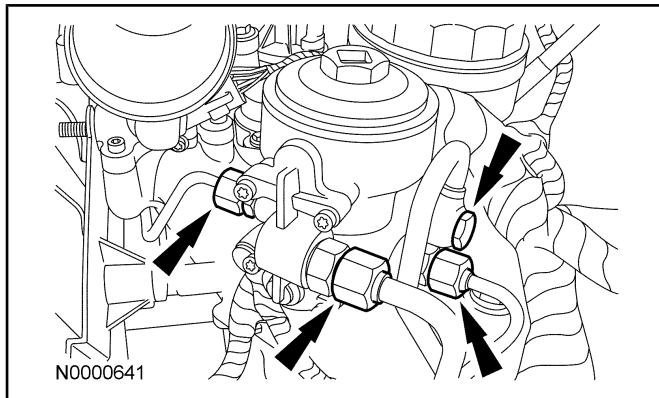

35. **NOTE:** It is necessary to remove the oil filter and drain the housing.

Remove the four bolts and the oil filter housing.

- Remove and discard the O-ring seal.

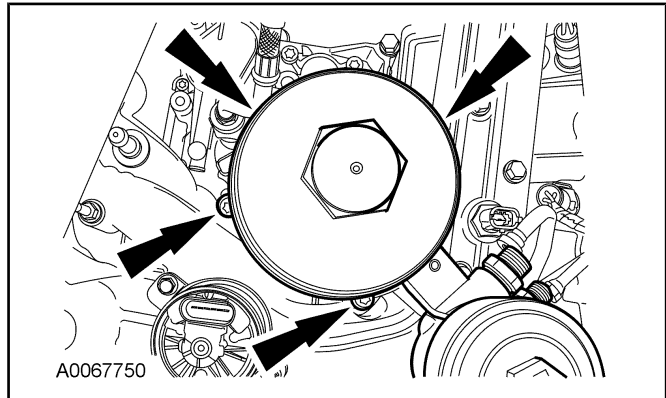

36. Remove the bolt and the oil filter return tube.

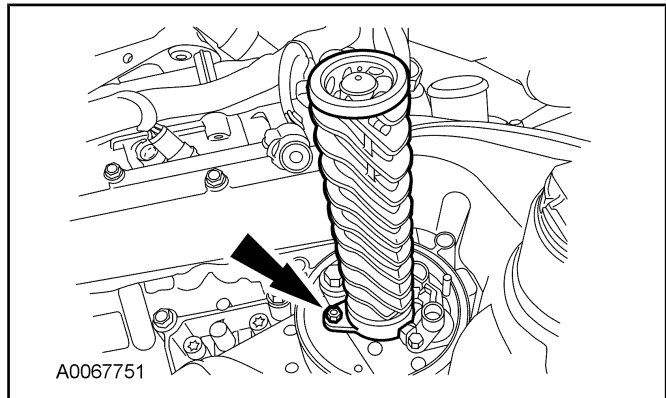

37. Remove the fuel tube.

- Remove the bolt, and the banjo bolt from the fuel tube.
- Discard the sealing washers and remove the fuel tube.

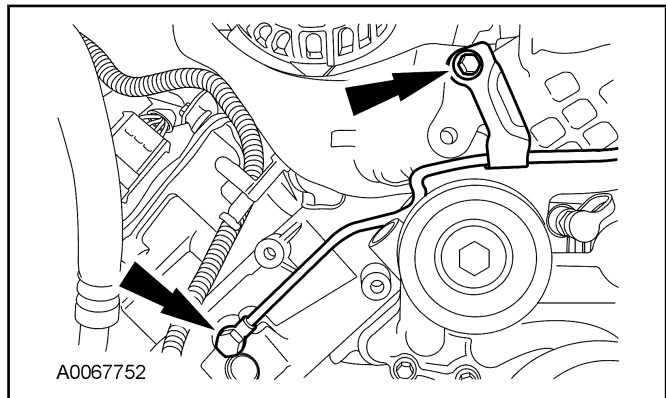

38. **NOTE:** Align the flat edge with the index feature located on the coolant supply port.

Pull the EGR cooler clamp forward, twist and then slide the EGR cooler hose rearward to remove.

IN-VEHICLE REPAIR(Continued)

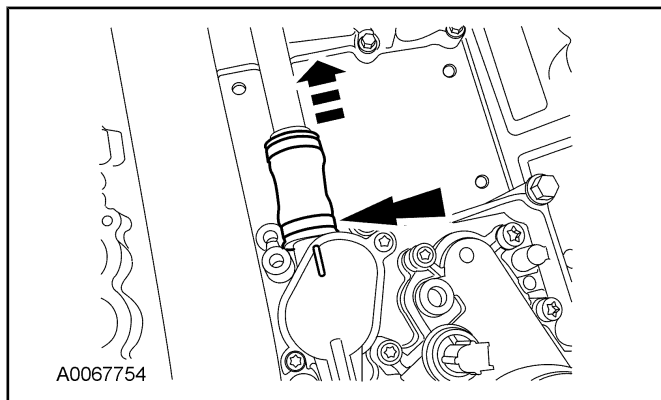

39. **NOTE:** LH shown, RH similar.

Loosen the nuts and bolts from the turbocharger adapter pipe.

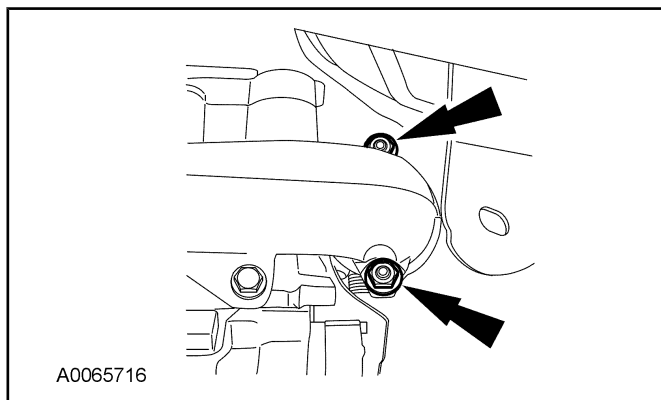

40. Loosen the EGR cooler V-clamp.

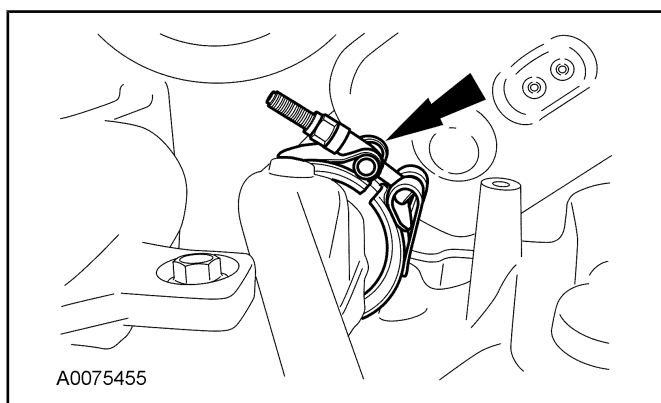

41. **NOTE:** Keep the EGR cooler V-clamp with the turbo adapter pipe.

Remove the bolts and the intake manifold.

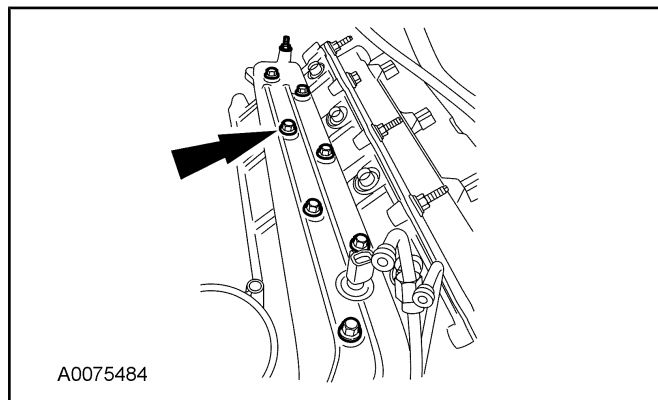

42. Remove the intake manifold gaskets.

- Clean and inspect the gaskets. Install new gaskets if necessary.
- Clean and inspect the sealing surfaces.

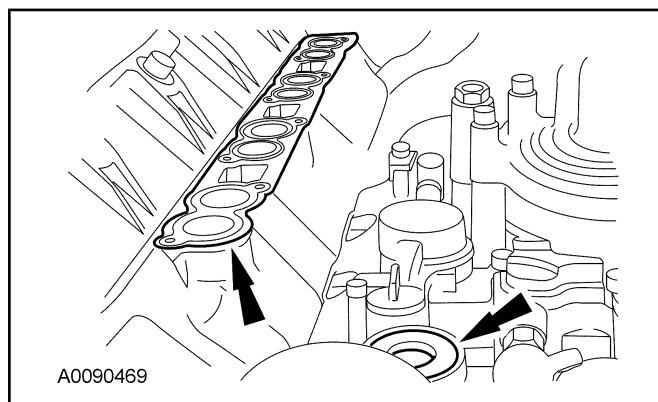

Installation

All vehicles

1. **NOTE:** The locating tabs on the gaskets must be up and positioned toward the center of the engine, or a leak will occur.

Install the intake manifold gaskets and front module O-ring seal.

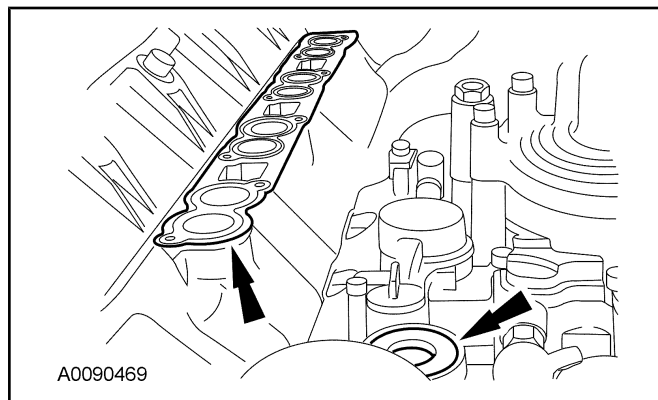

IN-VEHICLE REPAIR(Continued)

2. **NOTE:** When installing the manifold, apply a slight amount of all purpose grease to the mating surface of the EGR tube to keep the EGR gasket in place.

NOTE: Install the EGR cooler V-clamp loosely in place on the turbo adapter pipe.

Install the intake manifold and loosely install the bolts. Tighten the intake manifold bolts in the sequence shown.

- 1 Tighten bolts 9-16 to 11 Nm (8 lb-ft).
- 2 Tighten all bolts to 11 Nm (8 lb-ft) in the sequence shown.

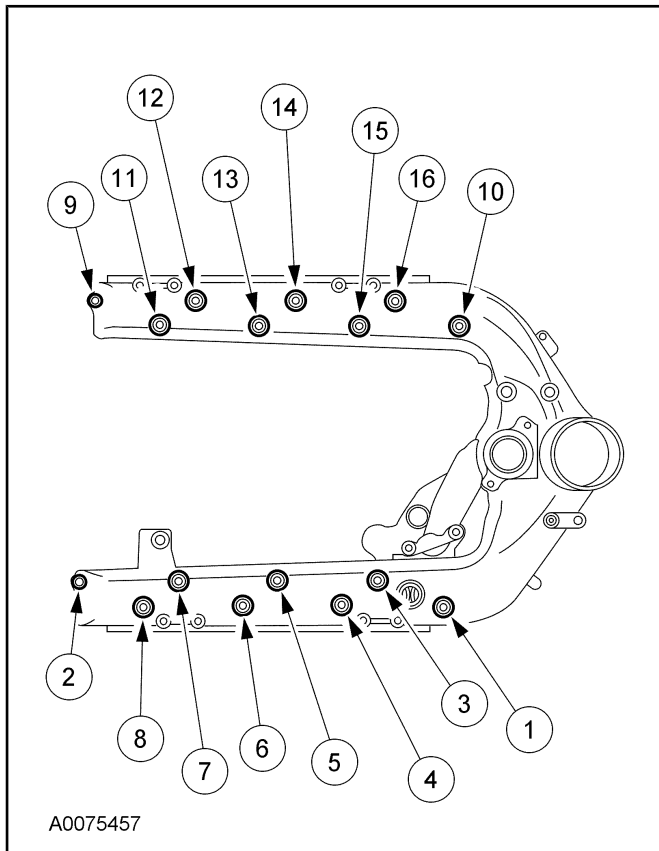

3. Position the EGR cooler V-clamp over the EGR tube.
4. Install the gasket and the EGR cooler V-clamp.

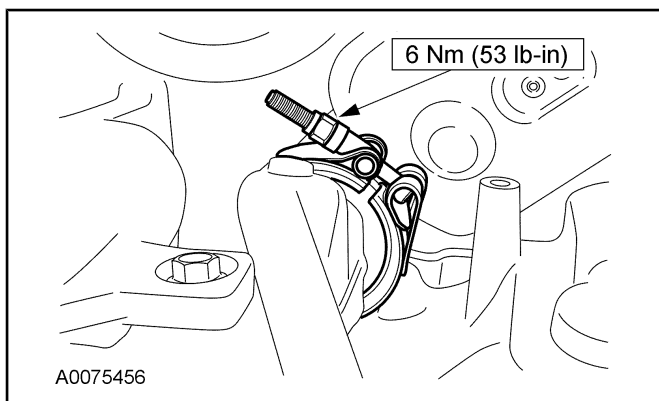

5. Slide the EGR cooler hose forward and rotate flat to lock.

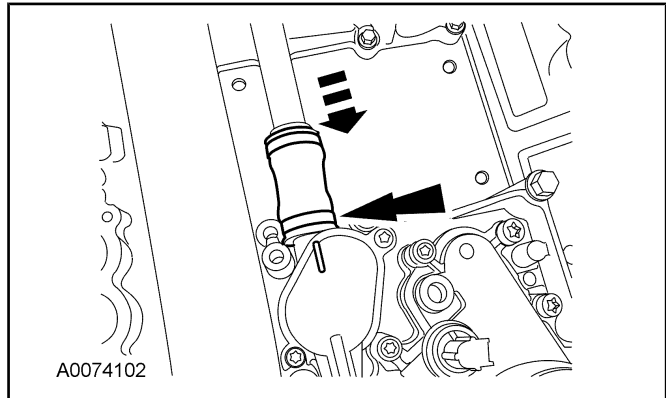

6. **NOTE:** Install new sealing washers on the banjo bolt.

Install the fuel tube.

- Install the bolt.
- Install the banjo bolt.

? For Viton® sealing washers, tighten to 25 Nm (18 lb-ft).

? For copper sealing washers, tighten to 38 Nm (28 lb-ft).

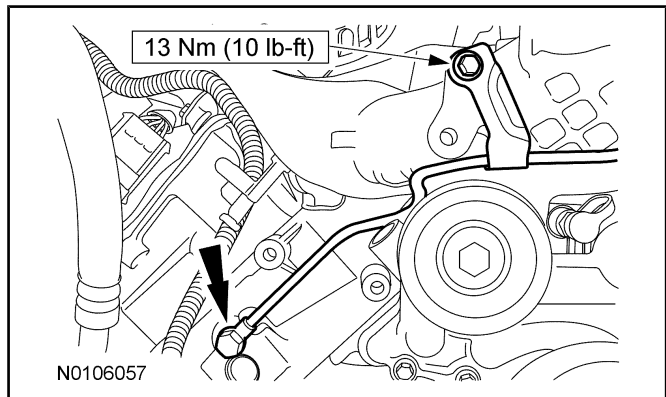

7. Install the oil filter return tube and bolt.
 - On new oil filter return tubes, tighten to 6 Nm (53 lb-in).
 - On used oil filter return tubes, tighten to 3 Nm (27 lb-in).

IN-VEHICLE REPAIR(Continued)

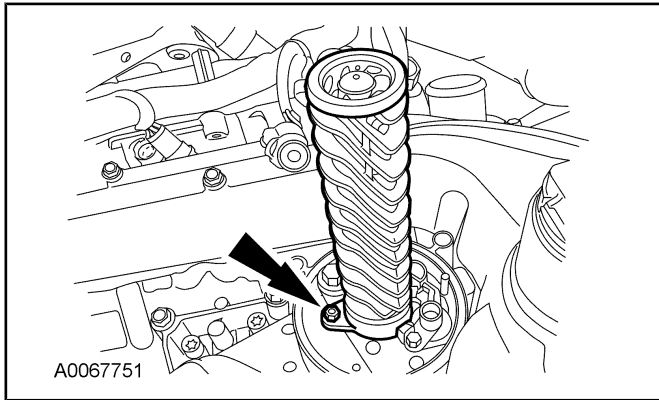

8. **NOTE:** Install a new O-ring seal.

Install the oil filter housing and the four bolts.

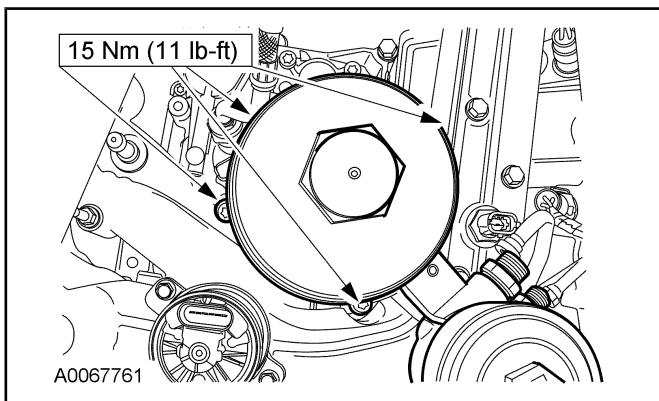

9. **NOTE:** Install new sealing washers on the banjo fitting.

Connect the fuel tube fittings.

- Tighten the banjo bolt.
 - ? For Viton® sealing washers, tighten to 28 Nm (21 lb-ft).
 - ? For copper sealing washers, tighten to 35 Nm (26 lb-ft).

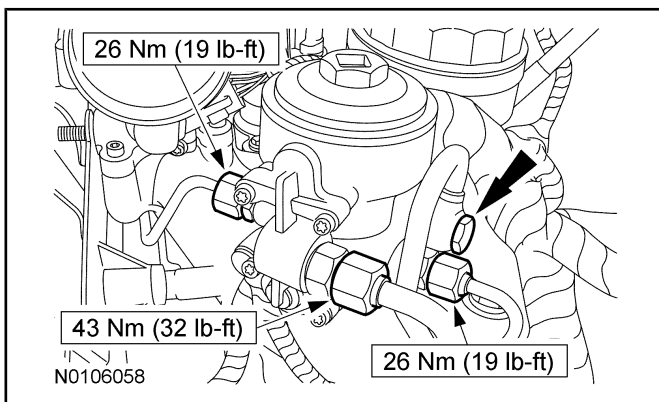

10. Position the fuel injector harness and install the retaining nut. Connect the eight fuel injectors electrical connectors.

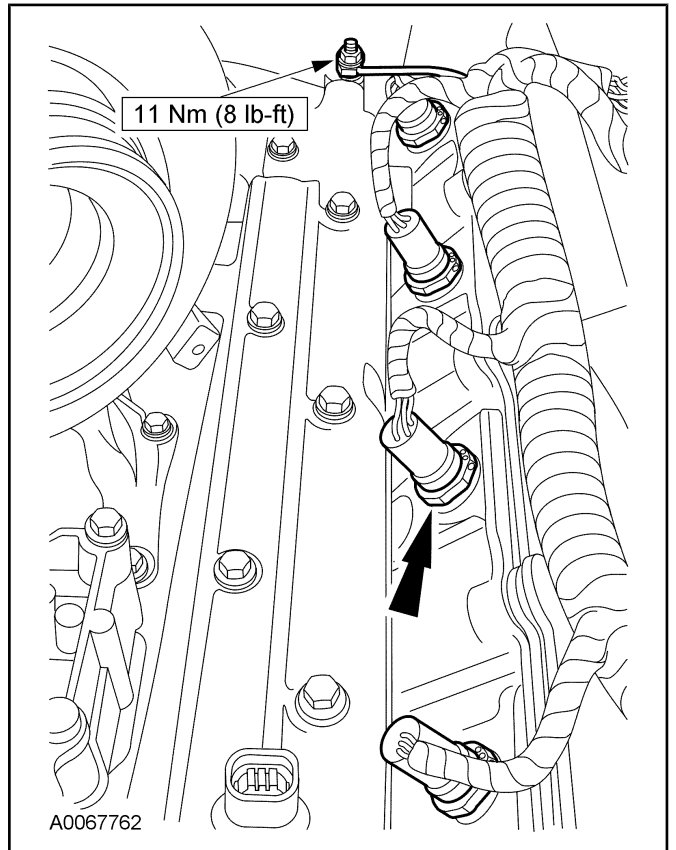

Early build vehicles

11. Connect the EP sensor electrical connector.

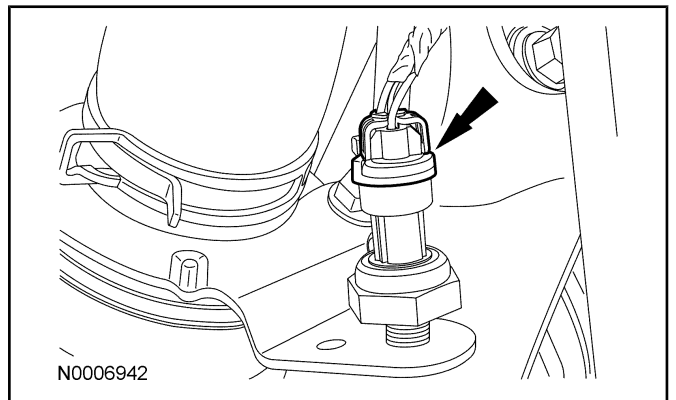

All vehicles

12. Connect the IAT2 sensor electrical connector.

IN-VEHICLE REPAIR(Continued)

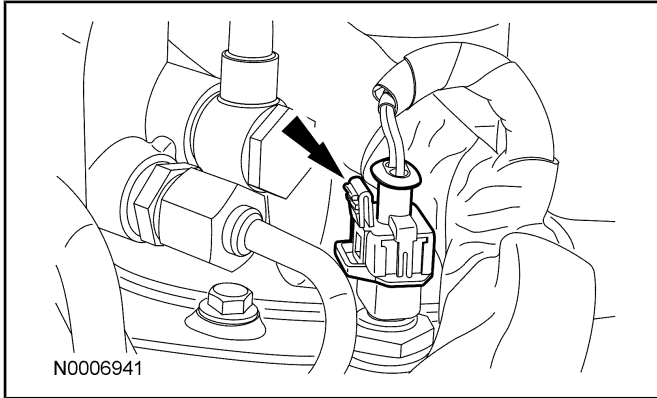

13. Connect the engine coolant temperature (ECT) sensor and the pin-type retainer.

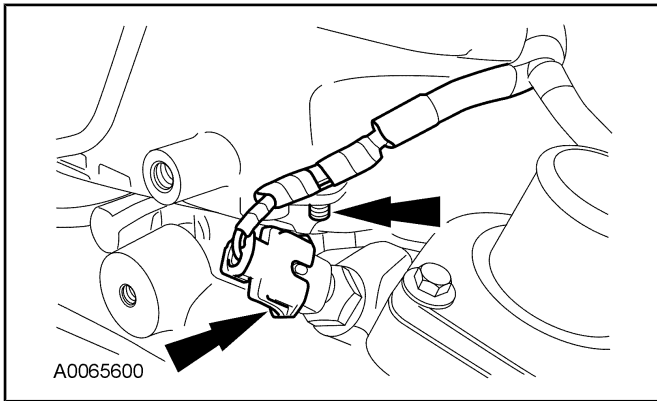

14. Connect the engine oil temperature (EOT) sensor electrical connector.

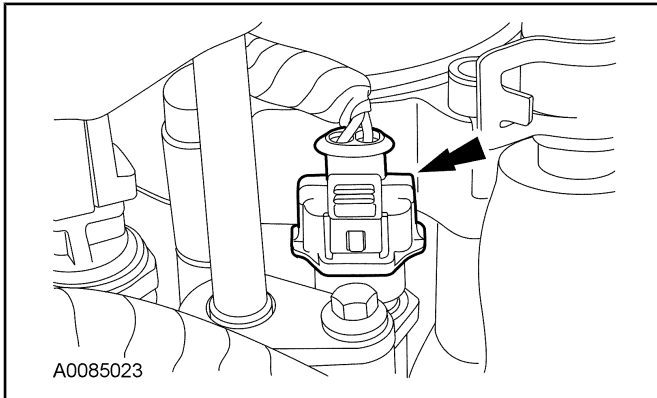

15. Connect the engine oil pressure (EOP) sensor electrical connector.

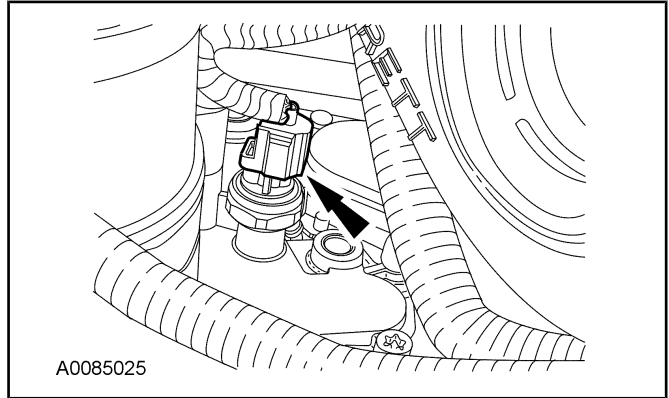

16. Connect the EGR valve electrical connector.

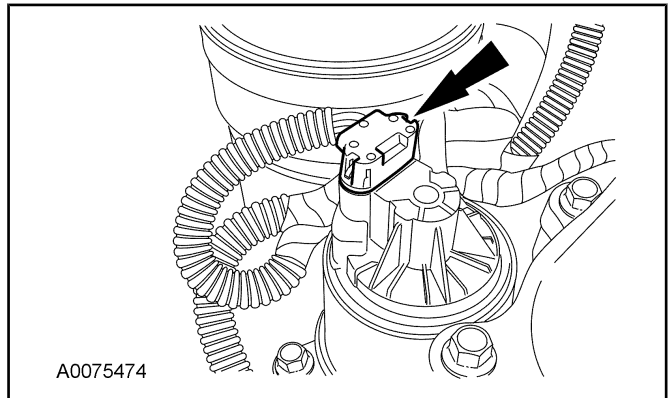

17. Connect the wiring retainer and injector pressure regulator electrical connector. Position back the heat insulating wrap.

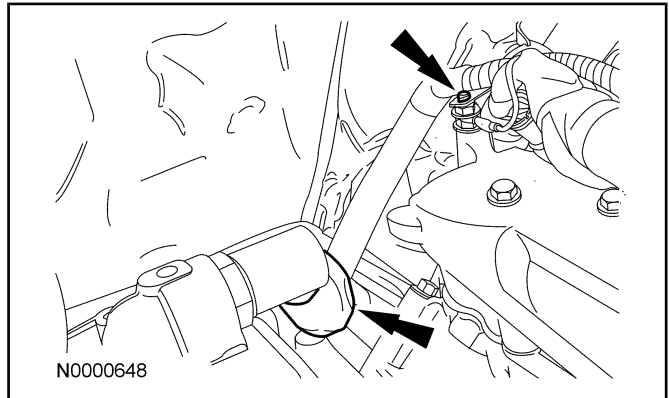

18. **NOTE:** Early build shown, late build similar.

Install the top two bolts to the injector IPR heat shield.

IN-VEHICLE REPAIR(Continued)

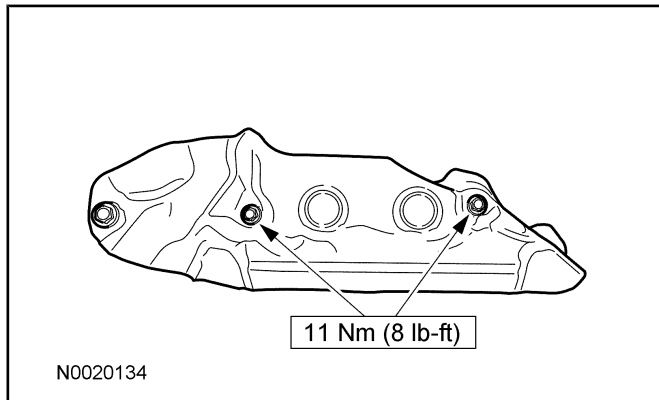

19. If equipped with a heat shield bracket, install the heat shield bracket and bolts.

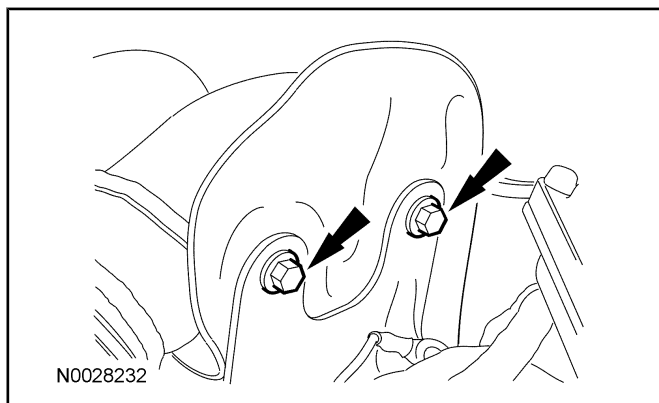

20. If equipped with a heat shield bracket, connect the wiring retainer to the back of the heat shield bracket.

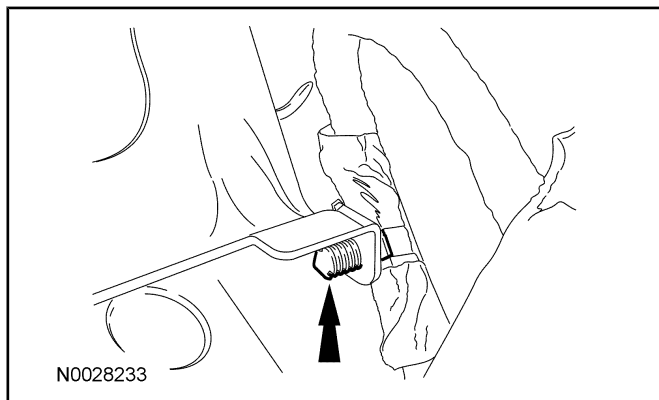

21. If equipped with a heat shield bracket, position back the ground wire and install the retaining nuts.

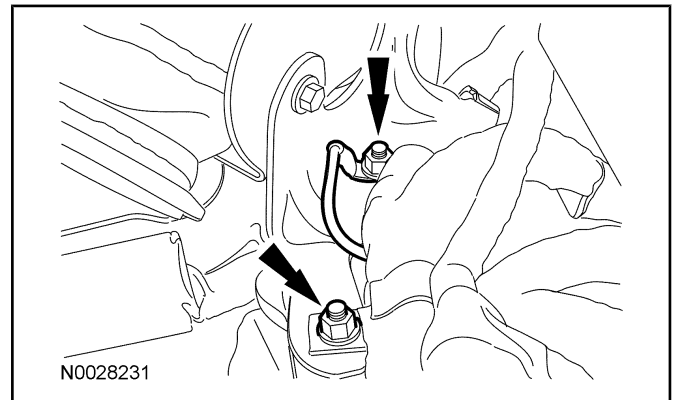

22. Install the fuel injector control module. For additional information, refer to Section 303-14B.

23. Connect the engine coolant vent hose and clamp.

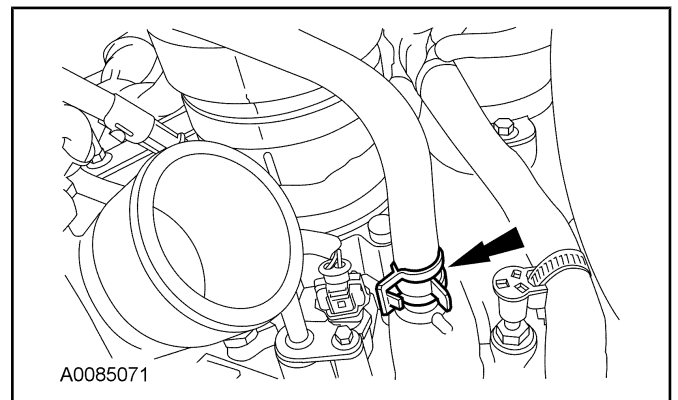

24. Connect the MAP sensor hose.

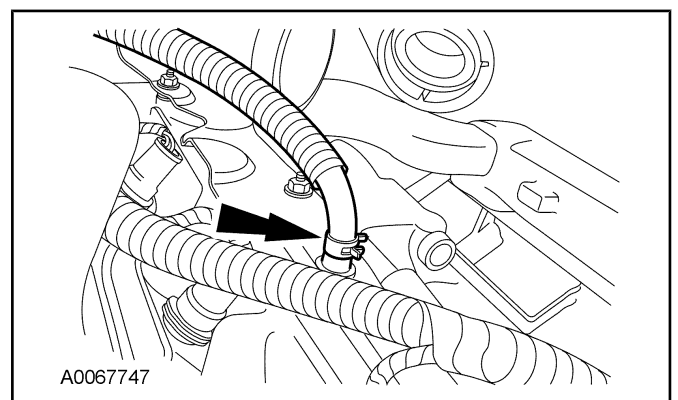

25. **NOTE:** Install a new O-ring seal on the heater hose tube.

Install the heater hose tube and bolts.

IN-VEHICLE REPAIR(Continued)

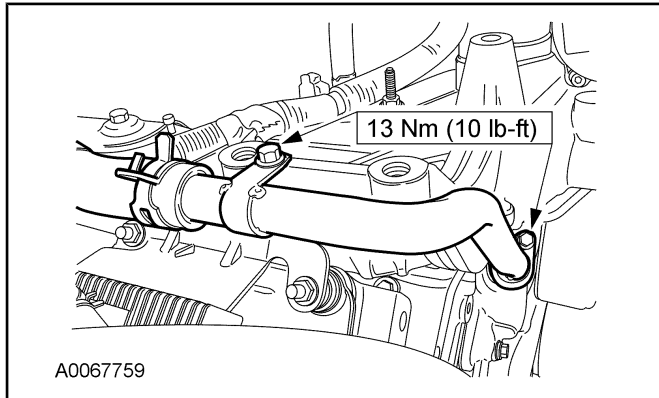

26. **NOTE:** Engine side shown, charge-air-cooler (CAC) side similar.

Install the CAC duct and tighten the clamps.

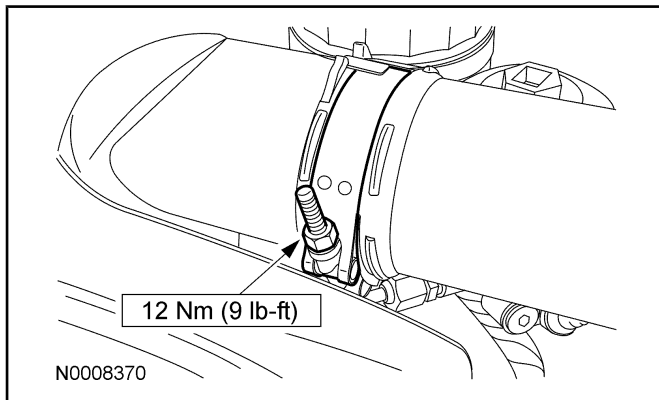

27. Install the turbocharger pedestal and turbocharger. For additional information, refer to Section 303-04D.

28. **NOTE:** Alternately tighten the bolts to specification.

Tighten the nuts and bolts in the adapter pipe.

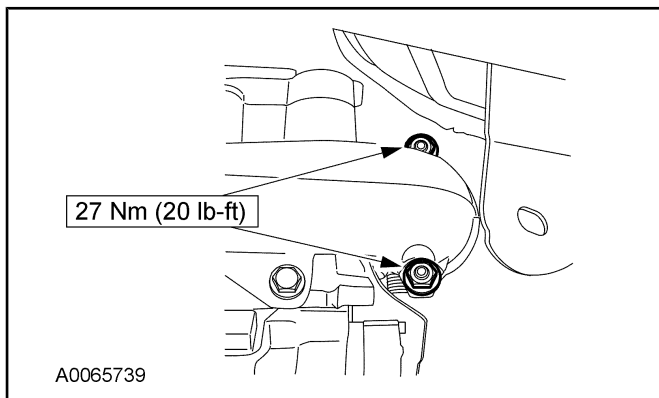

29. Install the generator and the three bolts.

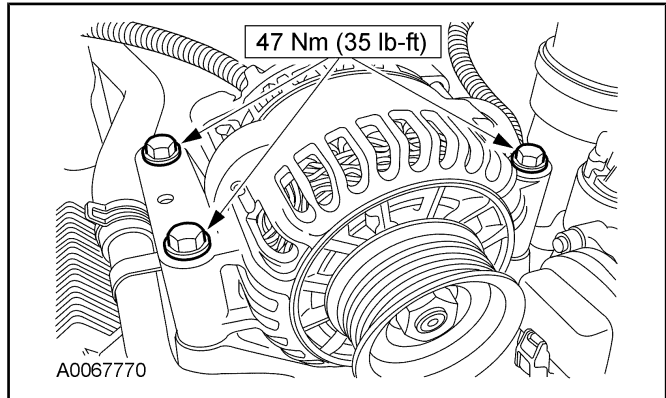

30. Connect the generator B+ wire land electrical connector and position the boot back.

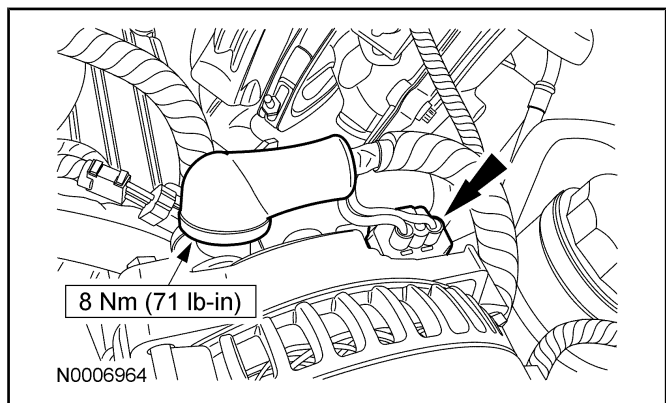

Vehicles with single generator

31. Install the accessory drive belt.

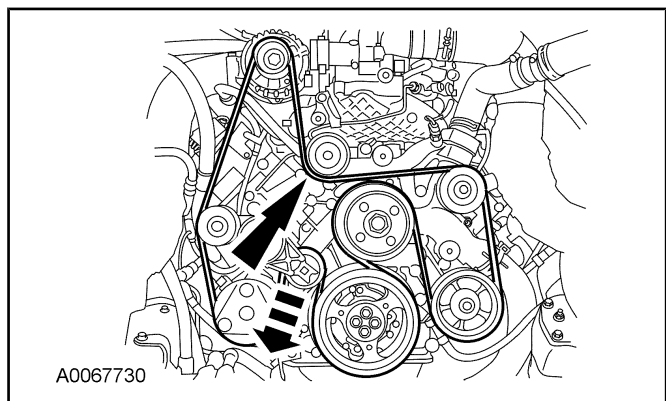

Vehicles with dual generators

32. Install the generator with mounting bracket and bolts.

IN-VEHICLE REPAIR(Continued)

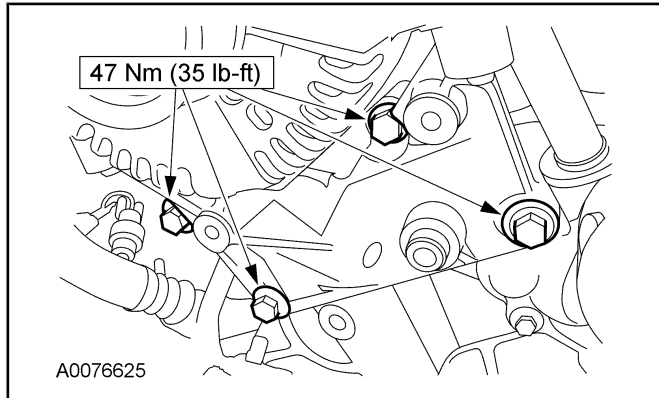

33. Connect the B+ wire, generator electrical connector and wire retainer.

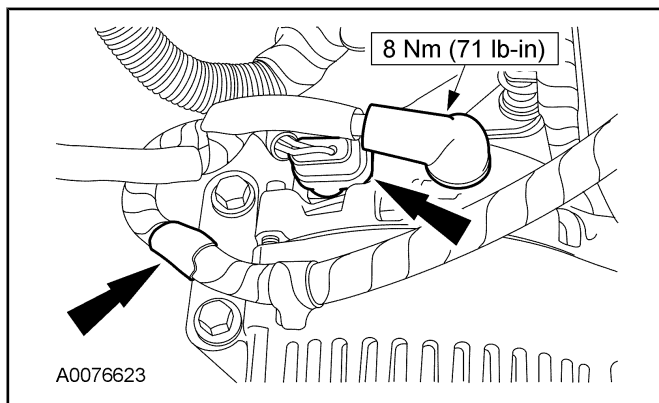

34. Install the accessory drive belt tensioner and bolts.

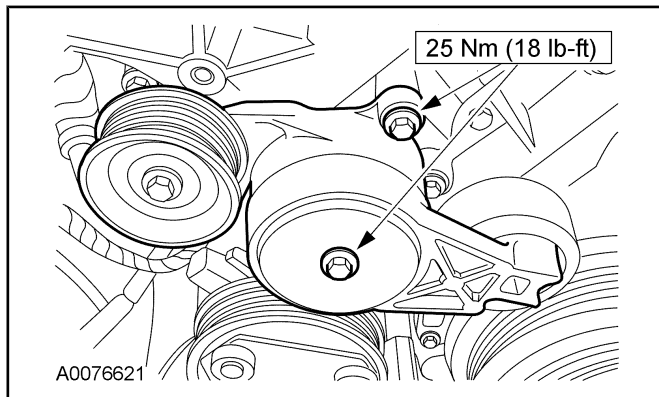

35. Position the accessory drive belt idler pulley. Install the bracket and bolts.

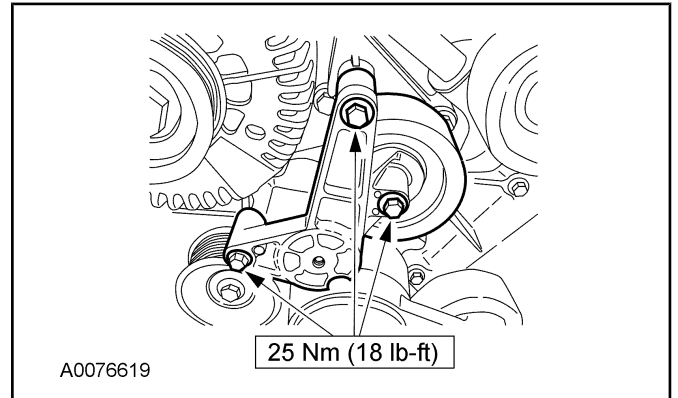

36. Install the accessory drive belt.

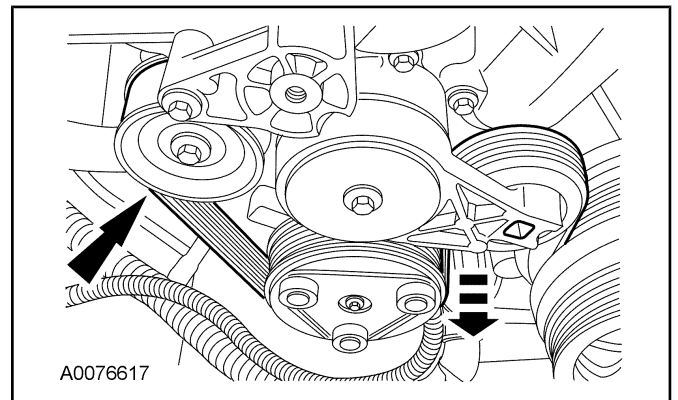

37. Install the accessory drive belt tensioner and bolt.

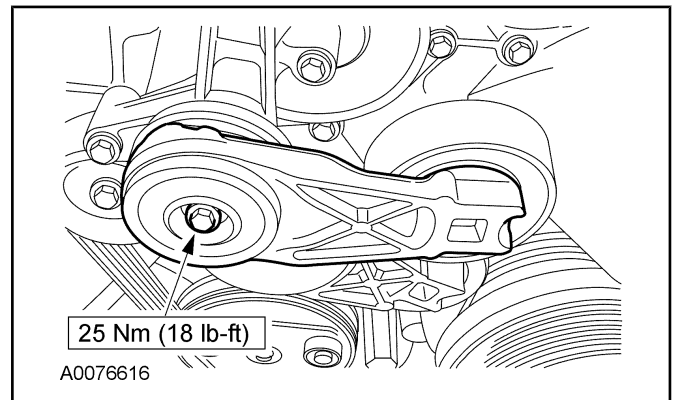

38. Install the accessory drive belt.

IN-VEHICLE REPAIR(Continued)

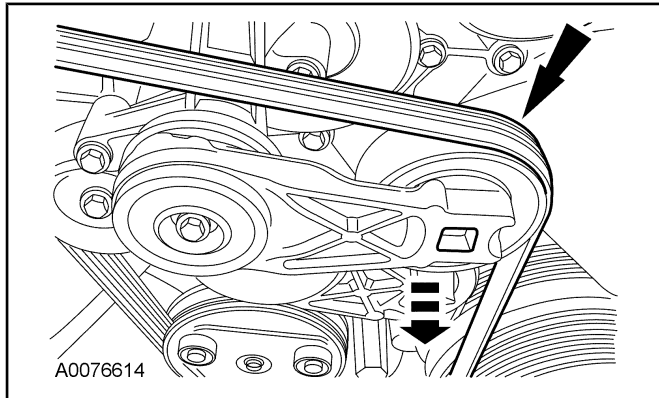

All vehicles

39. **NOTE:** Engine side shown, CAC side similar.

NOTE: If there is any oil residue, clean both connecting ports and the inside surface of the charge air cooler duct to prevent the duct from blowing off.

Install the turbocharger-to-CAC duct.

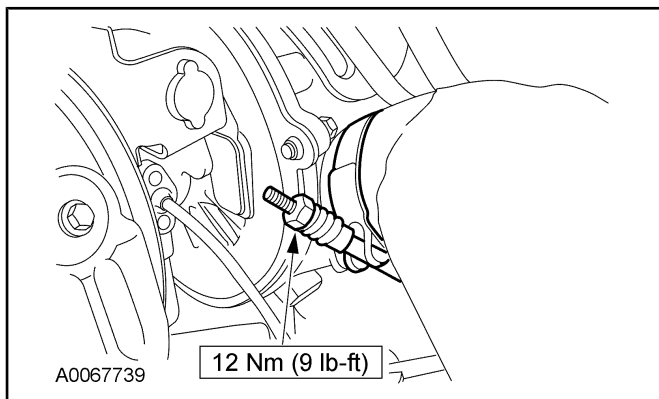

40. Install the upper radiator hose.

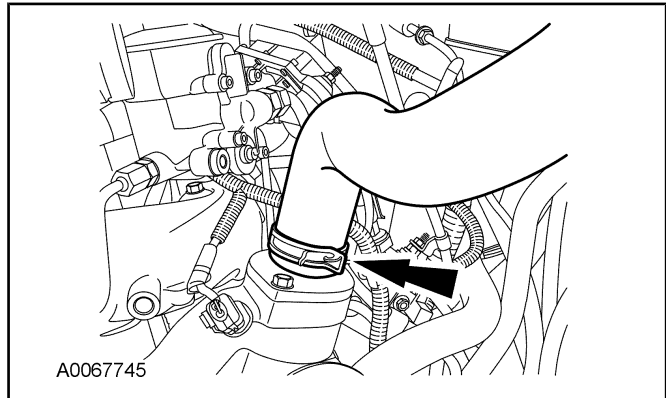

41. Install the degas bottle. For additional information, refer to Section 303-03.
42. Install the auxiliary battery. For additional information, refer to Section 414-01.
43. Install the cooling fan stator — 6.0L diesel engine. For additional information, refer to Section 303-03.